

PRE-INSULATED PIPES AND ACCESSORIES CATALOGUE

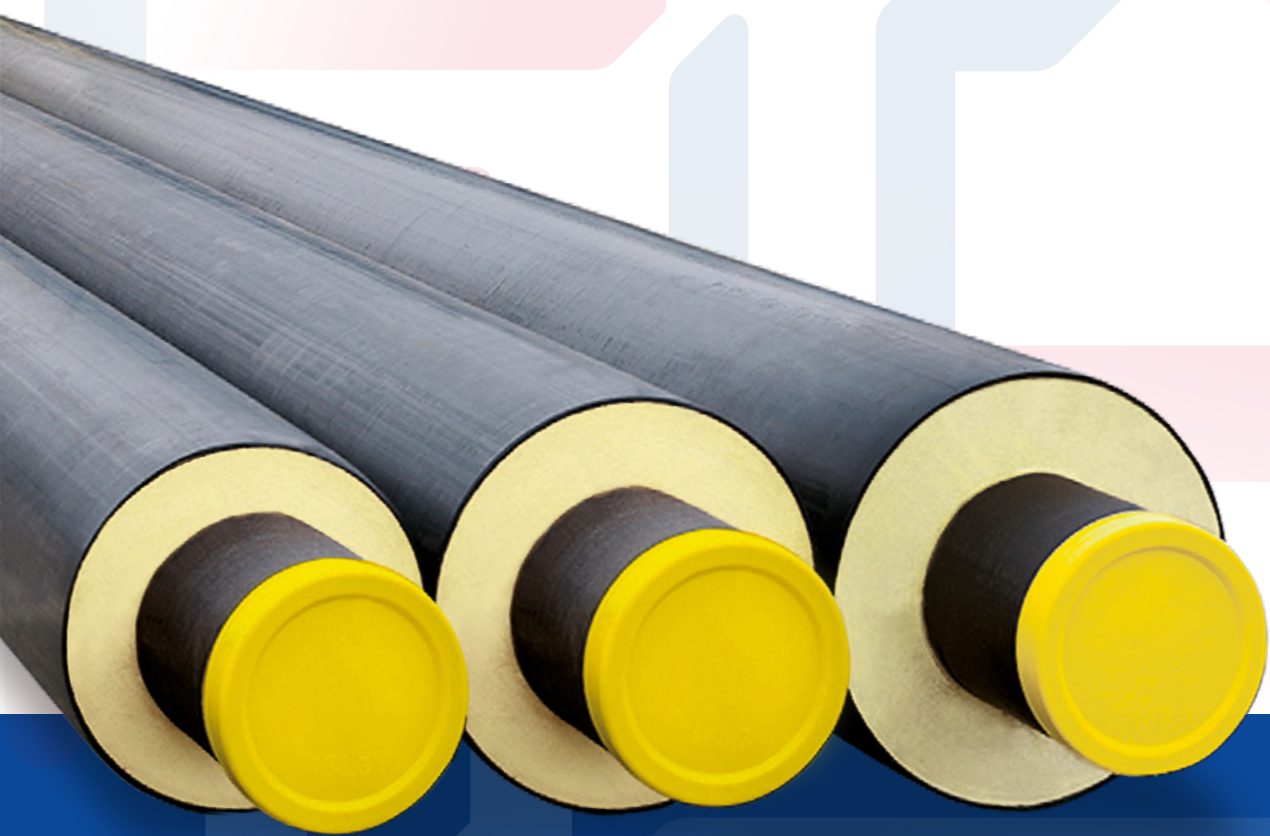

Introduction

Standard pre-insulated pipes offered in this catalogue are primarily used for heating or cooling distribution systems including the following applications: low temperature hot water heating, medium temperature hot water heating, high temperature hot water heating, primary hot water service, chilled water, condensate and others. However, other applications with specific materials are available upon request.

Alongside the portfolio provided below, our product range has expanded with the acquisition of 100% of HART - PIPE s.r.o. in 2023 to also include pre-insulated piping systems for long-distance steam distribution and other types of piping for special purposes, such as high-pressure gas distribution, cooling water for mine air conditioning, etc.

HART - PIPE s.r.o. also offers vacuum pipes of its own production designed mainly for steam distribution. This makes the portfolio of our two manufacturing plants more comprehensive, with a wide range of options for the customer to choose from. For any questions or specific requests concerning orders, please contact the sales representatives of Fintherm a.s. and/or HART-PIPE s.r.o. (see www.fintherm.as and www.hart-pipe.cz).

Fintherm® Standard

is used for heat distribution. It meets the requirements of European Association standards (including the German Association AGFW / FW401 and EUROHEAT & POWER), and the harmonised European standards EN 253, EN 448, EN 488, and EN 489 as amended. These pre-insulated pipes are manufactured from steel pipes insulated with hard polyurethane foam covered with a layer of polyethylene. The standard series is intended for a maximum working overpressure of 2,5 MPa and a maximum working temperature of 150°C (160°C on a short-term operating basis) with a service life of 30 years. In addition, we can offer pipes with increased thermal resistance of up to 160°C, also with a 30-year service life.

Fintherm® Standard Spiro

is used for above-ground heat distribution. These pre-insulated pipes are manufactured from steel pipes insulated with hard polyurethane foam, and covered with spiral overlaid steel zinc-coated sheets. The pipes are intended for a maximum working overpressure of 2,5 MPa and a maximum working temperature of 150°C (160°C on a short-term operating basis) with a 30-year service life. In addition, we can offer pipes with increased thermal resistance of up to 160°C, also with a 30-year service life.

Fintherm® Twins

is used for heat distribution. These pre-insulated pipes are manufactured from steel pipes insulated with hard polyurethane foam covered with a layer of polyethylene. The insulation is applied to the supply and return pipes, forming a pair. The pipes are manufactured in compliance with EN 15698-1. The standard series is intended for a maximum working overpressure of 2,5 MPa, a maximum working temperature of 130°C, and a maximum temperature difference of 50°C between the supply and return pipes, with a 30-year service life.

Fintherm® Special

In addition to the above standard systems, we manufacture pre-insulated pipes which can be produced in other materials according to customer requirements. FINTHERM® has extensive experience with the insulation of pipes for the chemical and refrigeration industries, water supply utilities, sanitation, and others. The long-term operating temperature range using polyurethane insulation is 150°C, and with up to 160°C for short-term operation. For higher operating temperatures of up to 160°C, we offer pipes with special polyurethane foam insulation, capable of handling higher temperatures. For media-carrying pipes, we can manufacture systems in steel, stainless steel, acid resistant material, galvanised steel, copper, polyethylene, polybutene, polypropylene, glass fibre, PEX, cast iron, and other material with polyethylene or metal spiral overlaid sheet depending on the specific application.

FINTHERM pipe systems are produced with Nordic system sensor wires as a standard, in compliance with EN 14 419. Pipes with other types of sensor wires (e.g., Brandes, Hagenuk, and Isotronic) can be supplied upon request.

FINTHERM® reserves the right to make changes without prior notice.

1 Fintherm® Standard

2 Fintherm® Standard Spiro Casing

3 Fintherm® Twins

4 Fintherm® Special

5 Accessories

6 Quality and Certifications

1 Fintherm[®] Standard

- 1.1 Technical specification**
- 1.2 Pipes**
- 1.3 Bends**
- 1.4 Elbows**
- 1.5 T-branches**
- 1.6 Reducers**
- 1.7 Anchors**
- 1.8 One time compensators**
- 1.9 Shut-off valves**
- 1.10 Drain/Air relief valves**
- 1.11 Combination valves**

Fintherm® Standard

1.1 Technical specification

1.1.1 Steel carrier pipe

The steel piping used in the FINTHERM system is made of longitudinally or helically welded pipes in compliance with the EN10217-1, EN10217-2, and EN10217-5 standards or, upon request, seamless pipes in accordance with EN10216-2. Unless otherwise stated, the values in this catalogue apply to welded pipes in compliance with the EN10217 standard.

Material:	P 235 GH, P 265 GH	
Certification:	EN 10204 - 3.1	
Bevelling:	DIN 2559/22, ISO 6761	
Lengths:	DN 25:	L = 6 m
	DN 32 - DN 80:	L = 6 m, 12 m
	DN 100 - DN 700:	L = 6 m, 12 m, 16 m
Density:	7850 kg/m ³	
Modulus of elasticity:	2,06 · 10 ⁵ N/mm ²	
Yield strength:	235 N/mm ²	
Tensile strength:	350 N/mm ²	
Heat conductivity:	46 - 54,5 W/mK	
Thermal expansion coefficient:	1,2 · 10 ⁻⁵ K ⁻¹	

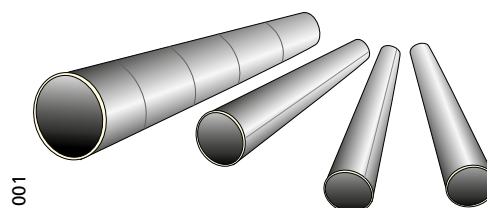

1.1.2 Rigid PUR insulation

Rigid polyurethane foam (PUR) is produced by mixing polyalcohols (polyols) containing additives and isocyanates (MDI). The mixture is injected into pipes using a high-pressure foaming technique. Cyclopentane or a gas of similar properties is used as the blowing agent. The PUR foam used in the Fintherm® Standard system is CFC-free and meets the stringent requirements of European Standard EN 253.

Average cell size:	≤ 0,5 mm
Closed cell content:	≥ 88 %
Core density:	≥ 60 kg/m ³
Compressive strength:	≥ 0,3 MPa
Water absorption:	≥ 0,12 MPa
Thermal conductivity (+ 50°C):	0,026 W/mK

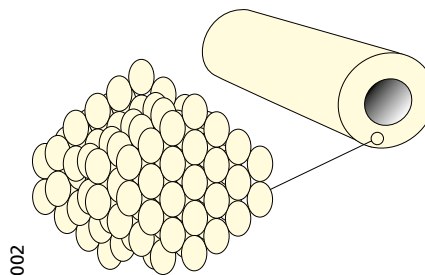

1.1.3 PE-HD casing pipe

Material PE-HD (high-density polyethylene)

Dimensions:	EN 253
Material:	PE-HD
Density (+20°C):	~ 960 kg/m ³
Heat conductivity:	0,43W/mK
Thermal expansion coefficient:	1,8 · 10 ⁻⁴ K ⁻¹
Melt flow index (MFI 190/5):	0,2 to 1,4
Carbon black content:	2,5 ± 0,5 % ASTM D-21603
Elongation at break:	≥ 350% ISO R-292
Impact strength:	≥ 10 mJ/mm ² ISO R-179
Tensile strength:	≥ 17 MPa ISO DIS 572B
The material is protected against the effects of UV radiation	

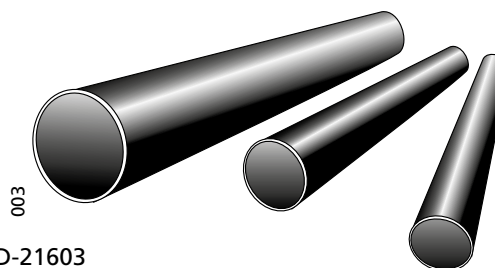

Fintherm® Standard

1.2 Pipes

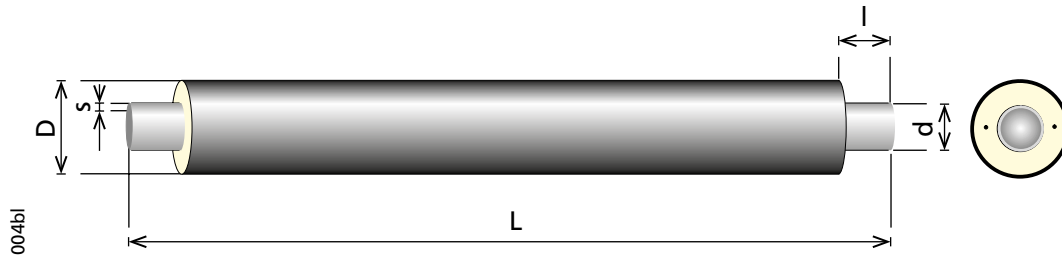

Insulation class 1

DN	d . s (mm)	D (mm)	L (m)	Weight (kg/m)	Insulation thickness (mm)	Water volume (l/m)
25	33,7 . 2,6	90	6	3,2	25	0,64
32	42,4 . 2,6	110	6, 12	4,1	31	1,09
40	48,3 . 2,6	110	6, 12	4,5	28	1,46
50	60,3 . 2,9	125	6, 12	5,9	29	2,33
65	76,1 . 2,9	140	6, 12	7,3	29	3,88
80	88,9 . 3,2	160	6, 12	9,1	33	5,35
100	114,3 . 3,6	200	6, 12, 16	13,2	40	9,01
125	139,7 . 3,6	225	6, 12, 16	16,0	39	13,79
150	168,3 . 4,0	250	6, 12, 16	20,7	37	20,18
200	219,1 . 4,5	315	6, 12, 16	30,4	44	34,67
250	273,0 . 5,0	400	6, 12, 16	43,4	59	54,30
300	323,9 . 5,6	450	6, 12, 16	56,1	58	76,80
350	355,6 . 5,6	500	6, 12, 16	64,1	66	93,20
400	406,4 . 6,3	560	6, 12, 16	81,7	70	121,80
450	457,0 . 6,3	630	6, 12	92,6	79	155,10
500	508,0 . 6,3	710	6, 12	107,2	92	192,80
600	610,0 . 7,1	800	6, 12	142,3	84	276,70
700	711,0 . 8,0	900	6, 12	185,6	82	377,60
800 to 1200 upon request						

The length of non-insulated ends also applies to the Fintherm Standard pre-insulated fittings.

Pipes can be manufactured in other lengths, dimensions, and insulation thicknesses upon request.

Lengths of the non-insulated pipe end:

≤ DN 350 l = 170 ± 10 mm

≥ DN 400 l = 190 ± 10 mm

Code: Fintherm® Standard (insulation class) P (DN/casing diameter) (length)

Ex.: FTS 1 P DN100/200 12m

Fintherm® Standard

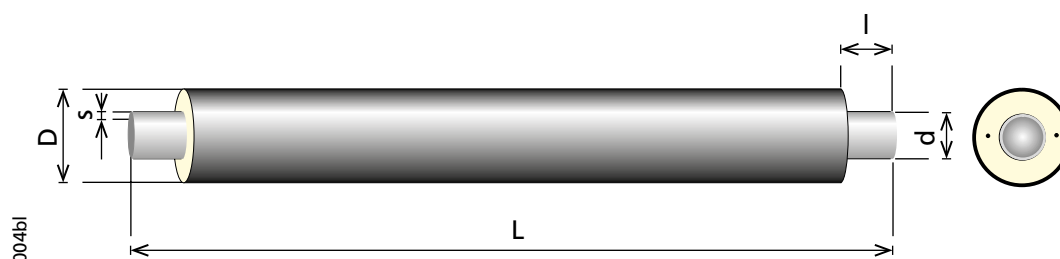

Insulation class 2

DN	d . s (mm)	D (mm)	L (m)	Weigh (kg/m)	Insulation thickness (mm)	Water volume (l/m)
25	33,7 . 2,6	110	6, 12	3,6	35	0,64
32	42,4 . 2,6	125	6, 12	4,5	38	1,09
40	48,3 . 2,6	125	6, 12	4,8	35	1,46
50	60,3 . 2,9	140	6, 12	6,3	37	2,33
65	76,1 . 2,9	160	6, 12	7,8	39	3,88
80	88,9 . 3,2	180	6, 12	9,7	43	5,35
100	114,3 . 3,6	225	6, 12, 16	14,1	52	9,01
125	139,7 . 3,6	250	6, 12, 16	17,1	52	13,79
150	168,3 . 4,0	280	6, 12, 16	22,2	52	20,18
200	219,1 . 4,5	355	6, 12, 16	32,8	63	34,67
250	273,0 . 5,0	450	6, 12, 16	47,0	83	54,30
300	323,9 . 5,6	500	6, 12, 16	61,0	82	76,80
350	355,6 . 5,6	560	6, 12, 16	70,1	95	93,20
400	406,4 . 6,3	630	6, 12, 16	89,3	104	121,80
450	457,0 . 6,3	710	6, 12	101,6	118	155,10
500	508,0 . 6,3	800	6, 12	120,0	135	192,80
600	610,0 . 7,1	900	6, 12	158,8	132	276,70
700	711,0 . 8,0	1000	6, 12	205,4	129	377,62
800 to 1200 upon request						

The length of non-insulated ends also applies to the Fintherm Standard pre-insulated fittings.

Pipes can be manufactured in other lengths, dimensions, and insulation thicknesses upon request.

Lengths of the non-insulated pipe end:

≤ DN 350 l = 170 ± 10 mm

≥ DN 400 l = 190 ± 10 mm

Code: Fintherm® Standard (insulation class) P (DN/casing diameter) (length)

Ex.: FTS 2 P DN100/225 12m

Fintherm® Standard

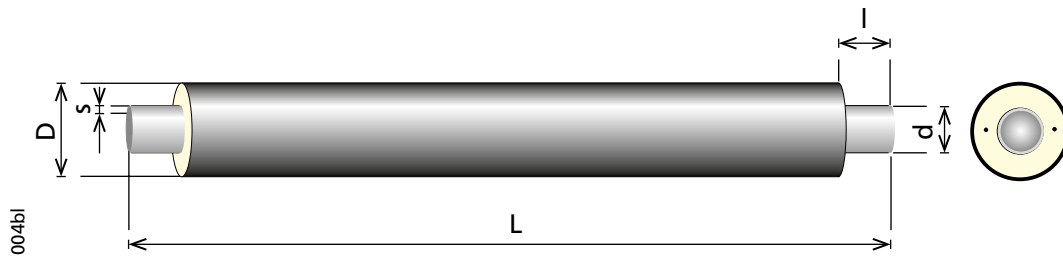

Insulation class 3

DN	d . s (mm)	D (mm)	L (m)	Weight (kg/m)	Insulation thickness (mm)	Water volume (l/m)
25	33,7 . 2,6	125	6, 12	4,0	43	0,64
32	42,4 . 2,6	140	6, 12	4,9	46	1,09
40	48,3 . 2,6	140	6, 12	5,2	43	1,46
50	60,3 . 2,9	160	6, 12	6,9	47	2,33
65	76,1 . 2,9	180	6, 12	8,5	49	3,88
80	88,9 . 3,2	200	6, 12	10,4	52	5,35
100	114,3 . 3,6	250	6, 12, 16	15,2	64	9,01
125	139,7 . 3,6	280	6, 12, 16	18,5	66	13,79
150	168,3 . 4,0	315	6, 12, 16	23,9	69	20,18
200	219,1 . 4,5	400	6, 12, 16	35,7	86	34,67
250	273,0 . 5,0	500	6, 12, 16	51,9	107	54,30
300	323,9 . 5,6	560	6, 12, 16	67,0	111	76,80
350	355,6 . 5,6	630	6, 12, 16	77,8	129	93,20
400	406,4 . 6,3	710	6, 12	95,1	143	121,80
450	457,0 . 6,3	800	6, 12	116,0	161	155,10
500	508,0 . 6,3	900	6, 12	133,1	183	192,80
600 to 1200 upon request						

The length of non-insulated ends also applies to the Fintherm Standard pre-insulated fittings.

Pipes can be manufactured in other lengths, dimensions, and insulation thicknesses upon request.

Lengths of the non-insulated pipe end:

≤ DN 350 l = 170 ± 10 mm

≥ DN 400 l = 190 ± 10 mm

Code: Fintherm® Standard (insulation class) P (DN/casing diameter) (length)

Ex.: FTS 3 P DN100/250 12m

Fintherm® Standard

1.3 Bends

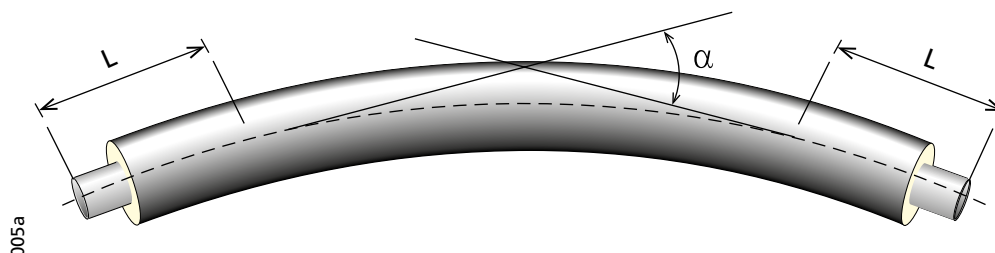

Straight ends of bends are approx. 2.5 m long (dimension "L" as above drawing).

Bends are produced on special forming equipment and are based on an advance customer order which specifies the required angle. The benchmark for determining the specific angle α is the angle measured at the central axis of the trench, taking into account the length of the straight ends. The standard straight pipes can be formed on site up to dimension DN 100 and bending angle up to 15°.

DN	Maximum bending angle α
32-65	45°
80-150	35°
200	25°
250	19°
300	16°
350	15°
400	10°
450	8°
500	5°

The values given are for 12 m pipes.

Important note:

We recommend that trench space is suitable for the specific shape of the bends with straight ends delivered.

Code: Fintherm® Standard (insulation class) PB (DN/casing diameter) (length)

Ex.: FTS 2 PB DN100/225 12 m 18°

Fintherm® Standard

1.4 Elbows

1.4.1 Standard elbows

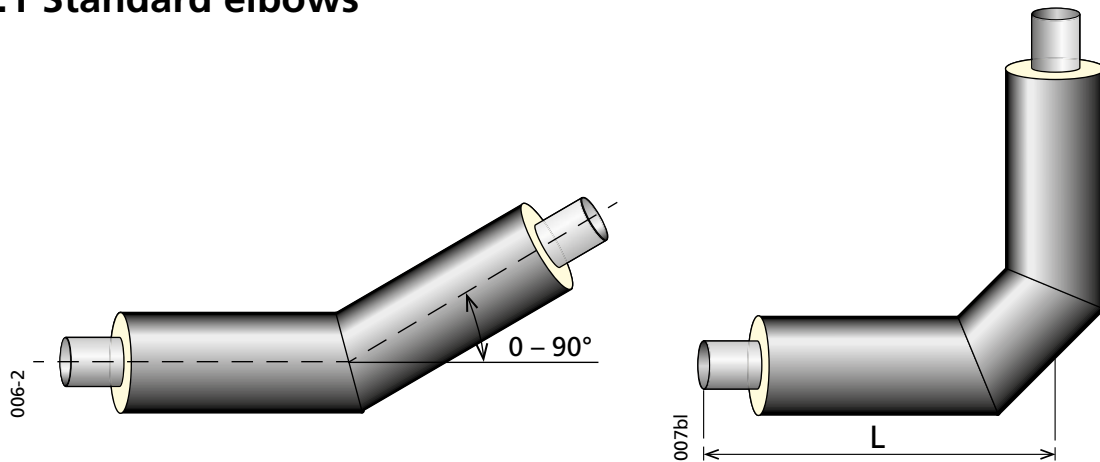

Fintherm® Standard prefabricated insulated elbows are manufactured with a standard angle of 90°. The bending radii, branch lengths and radii depend on pipe dimensions, see the table below. Other angles, branch lengths and radii of elbows can be manufactured upon request, subject to prior arrangement with FINTHERM a.s.

DN	Standard angle 90°			Atypical angles - other than 90°		
	L (mm)	R (mm)	R	L (mm)	R (mm)	R
25	1000	112	3D	1000	112	3D
32	1000	130	3D	1000	130	3D
40	1000	150	3D	1000	150	3D
50	1000	190	3D	1000	190	3D
65	1000	232	3D	1000	232	3D
80	1000	274	3D	1000	274	3D
100	1000	340	3D	1000	340	3D
125	1000	350	2,5D	1000	190	1,5D
150	1000	421	2,5D	1000	229	1,5D
200	1000	510	2,5D	1000	305	1,5D
250	1000	650	2,5D	1000	381	1,5D
300	1500	775	2,5D	1000	457	1,5D
350	1600	850	2,5D	1000	533	1,5D
400	1600	970	2,5D	1000	610	1,5D
450	-	-	-	1000	686	1,5D
500	1600	1245	2,5D	1200	762	1,5D

We can supply bending radii other than those listed upon request.

Code: Fintherm® Standard (insulation class) E (DN/casing diameter) (angle)

Ex.: FTS 1 E DN40/110 90°

Fintherm® Standard

1.4.2 Pipes Elbows with Extended Sections

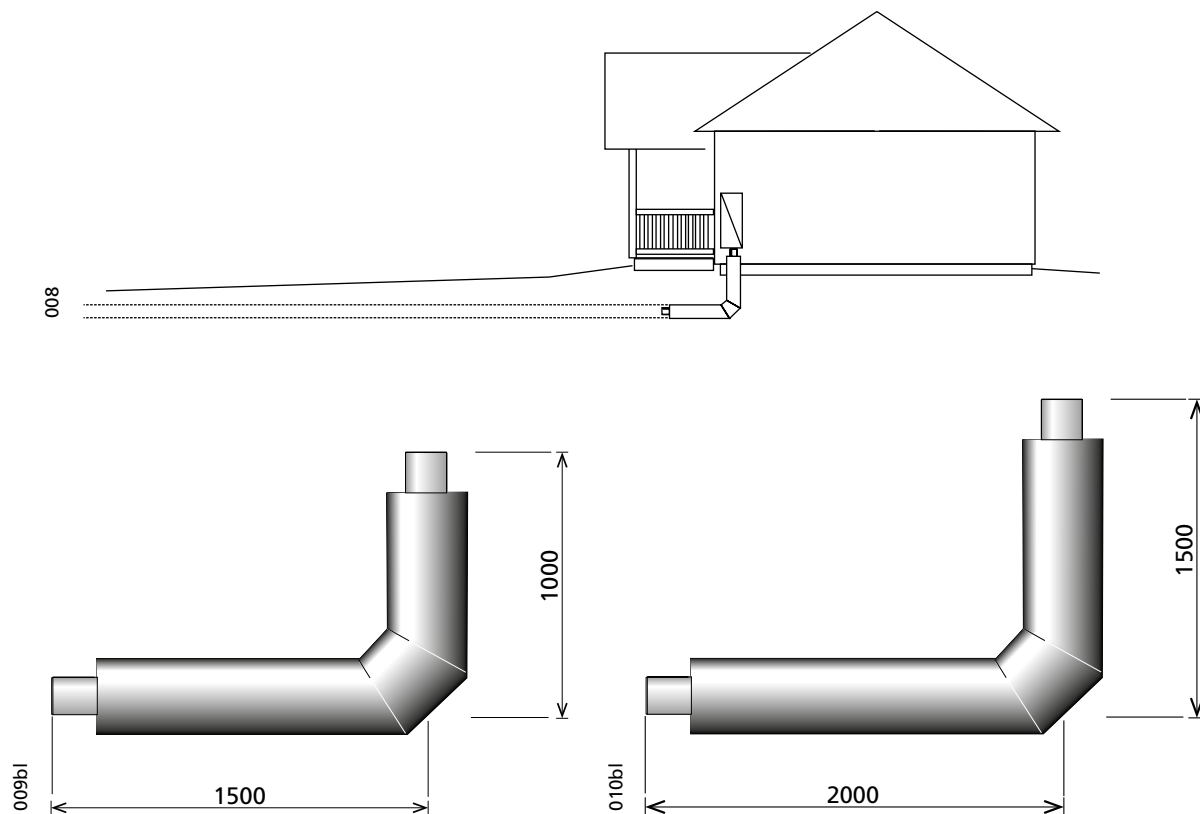

Pipe elbows with extended sections are standardly manufactured in dimensions DN25 – DN250, with section lengths of 1x1.5 m and 1.5x2 m. They serve primarily for the connection of units through foundation/floor. If needed, they can also be used anywhere else along the route, for instance in “U” expansion bends or in places where it is not possible to place a connection for layout reasons.

Code: Fintherm® Standard (insulation class) E (DN/casing diameter)
 (L = longer dimension of the arm x shorter dimension of the arm)
 Ex.: FTS 1 E DN50/125 L = 2,0x1,5m

Fintherm® Standard

1.5 T-branches

The following are used to branch off the main pipe:

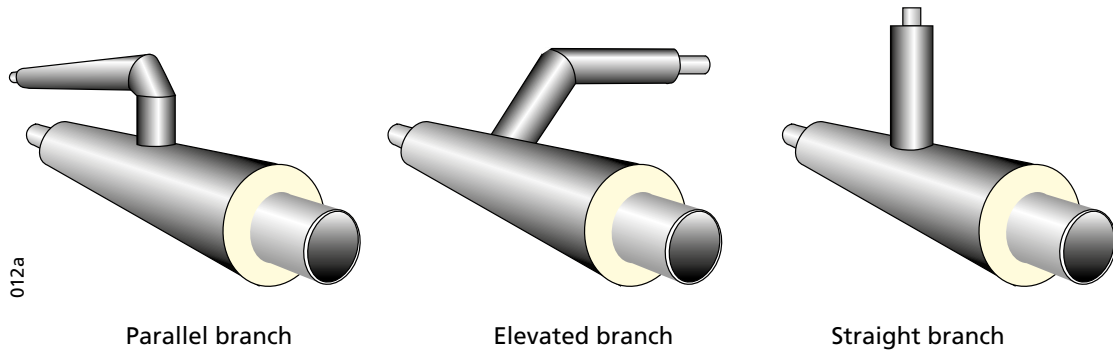

Implementation of the steel T-branch from the main route:

1) Necked-Out (Collaring) T-branch Standard T-piece

Standard design using the cold-forming method for the neck and the "V" weld. An advantage of this design is the higher overall strength of the "V" weld compared to a fillet weld, and better shape for the flow of the medium.

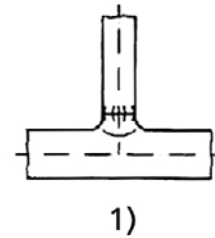

2) Prefabricated T-piece

Welded prefabricated T-pieces according to EN 10253-2 are used if there is a requirement for significantly higher strength or if the branch has the same dimension as the base.

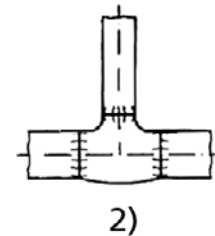

3) Welded tube fitting

In exceptional cases, when it is not technologically possible to use another construction method for the branch, branching with a fillet weld is used. Construction with reinforcement is also possible.

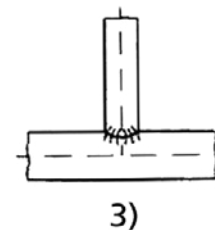

015

Most branches are also available with larger wall thicknesses for greater strength. It is recommended to consult the specific type and wall thickness with FINTHERM® technical department concerning the wall thickness, or determining such requirement based on static strength calculations according to the specific conditions of the project.

Fintherm® Standard

1.5.1 Parallel T-branches

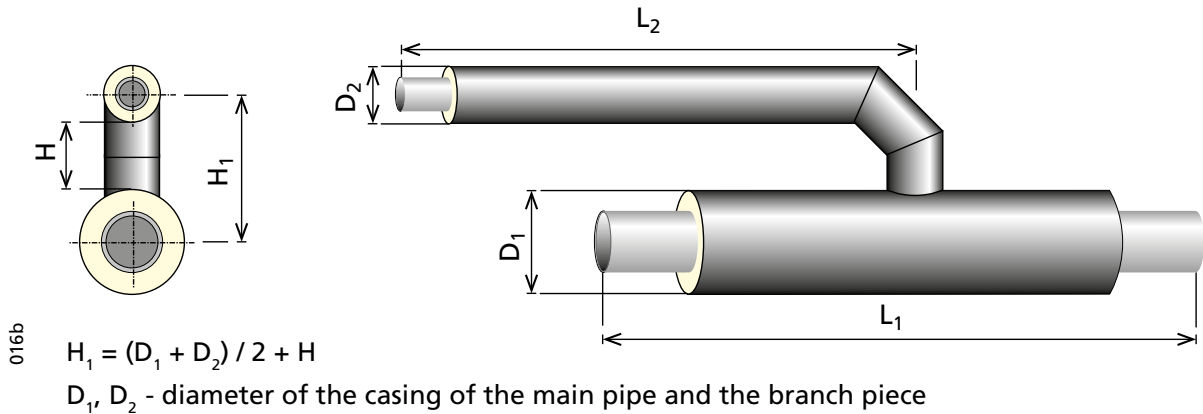

H - distance between the surfaces of the casing pipes

Arm lengths and distance between the surfaces of the casing pipes according to the dimensions of the branch piece:

DN ₂ 25 - DN ₂ 50:	L ₁ = 1000 mm,	L ₂ = 1000 mm,	H = 120 mm
DN ₂ 65 - DN ₂ 100:	L ₁ = 1000 mm,	L ₂ = 1000 mm,	H = 200 mm
DN ₂ 125 - DN ₂ 200:	L ₁ = 1200 mm,	L ₂ = 1000 mm,	H = 200 mm
DN ₂ 250 - DN ₂ 300:	L ₁ = 1500 mm,	L ₂ = 1000 mm,	H = 300 mm

Larger sizes and lengths different to L₁ and L₂ are available upon request.

Example of the location of expansion pads:

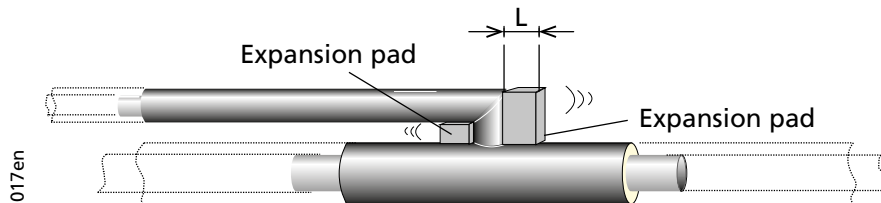

To allow pipe movement in the axial direction of the branch, it is necessary to insert foam pads on both sides of the branch. The length L is designed according to the movement of the branch and possible compression of the expansion pads upon the thermal expansion of the pipe.

Code: Fintherm® Standard P-T (insulation Class-DN of the main route/casing diameter) x (insulation Class-DN of the branch/casing diameter)

Ex.: FTS P-T 1-DN100/200 x 1-DN65/140

Fintherm® Standard

1.5.2 Elevation T-branches

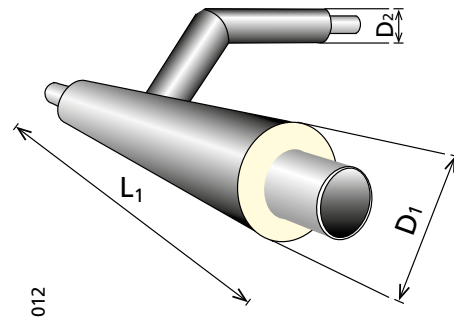
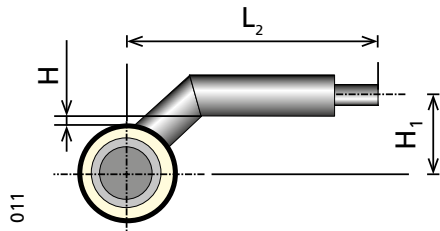

$$H_1 = (D_1 + D_2) / 2 + H$$

D_1, D_2 - diameter of the casing of the main pipe and the branch piece

$H = 35$ mm distance between the surfaces of the casing pipes

Arm lengths according to the dimensions of the branch piece:

DN₂ 25 - DN₂ 100: L₁ = 1000 mm L₂ = 1000 mm

DN₂ 125 - DN₂ 200: L₁ = 1200 mm L₂ = 1000 mm

DN₂ 250 - DN₂ 300: L₁ = 1500 mm L₂ = 1300 mm

Larger sizes and lengths different to L₁ and L₂ are available upon request.

The table indicates the distance H₁ between the axis of the main pipe and the branch piece for insulation class 1:

DN ₂ \ DN ₁	25	32	40	50	65	80	100	125	150	200	250	300
25	125											
32	135	145										
40	135	145	145									
50	143	153	153	160								
65	150	160	160	168	175							
80	160	170	170	178	185	195						
100	180	190	190	198	205	215	235					
125	193	203	203	210	218	228	248	260				
150	205	215	215	223	230	240	260	273	285			
200	238	248	248	255	263	273	293	305	318	350		
250	280	290	290	298	305	315	335	348	360	393	435	
300	305	315	315	323	330	340	360	373	385	418	460	485
350	330	340	340	348	355	365	385	398	410	443	485	510
400	360	370	370	378	385	395	415	428	440	473	515	540
450	360	370	370	378	385	395	415	428	440	473	515	540
500	395	405	405	413	420	430	450	463	475	508	550	575
600	435	445	445	453	460	470	490	503	515	548	590	615

Code: Fintherm® Standard E-T (insulation Class-DN of the main route/casing diameter) x (insulation Class-DN of the branch/casing diameter)

Ex.: FTS E-T 1-DN80/160 x 1-DN65/140

Fintherm® Standard

Methods of implementation of the elevation branch from the main route are:

- 1) use of the T-elevation branch, T straight branch,
(branched pipe returns to the same height as that of the main pipe after crossing the adjacent pipe)
- 2) use of two T-elevation branches
(branched pipe is at a different height than the main pipe)

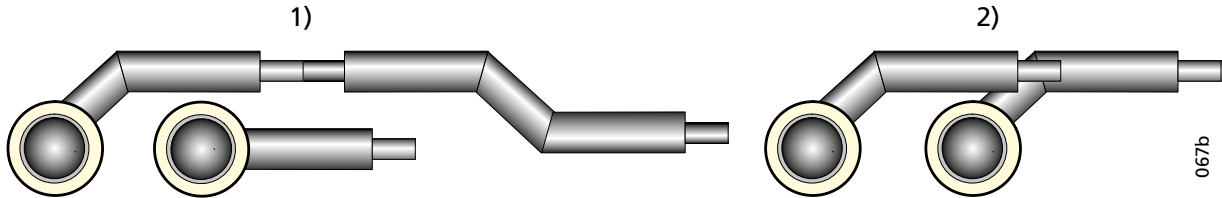

1.5.3 Straight T-branches

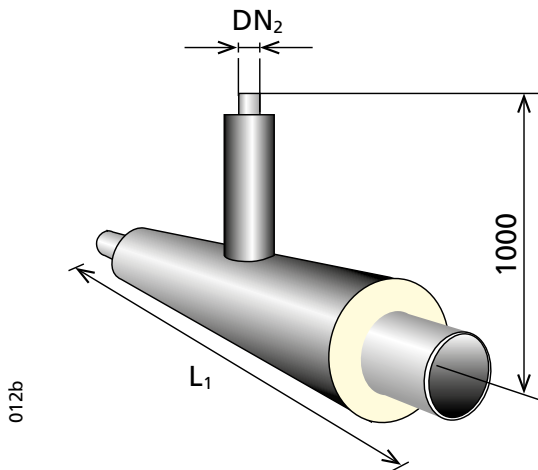

Lengths of the main pipe according to the dimensions of the branch piece:

- DN₂ 25 - DN₂ 100: L₁ = 1000 mm
- DN₂ 125 - DN₂ 200: L₁ = 1200 mm
- DN₂ 250 - DN₂ 300: L₁ = 1500 mm

Larger sizes and lengths are available upon request.

Code: Fintherm® Standard S-T (insulation Class-DN of the main route/casing diameter) x (insulation Class-DN of the branch/casing diameter)

Ex.: FTS S-T 1-DN80/160 x 1-DN65/140.

1.5.4 T-jumps

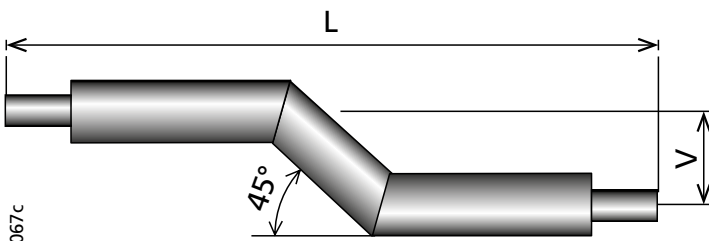

Dimensions of recoils:

This is a custom-made product with recoil heights and lengths set according to production capability; we encourage you therefore to consult with FINTHERM® technical department regarding the required values.

Fintherm® Standard J (insulation Class-DN of the main pipe/casing diameter) (V=recoil height) (L=recoil length)

FTS J 1-DN65/140 V=205 mm L=1500 mm

Fintherm® Standard

1.5.5 T-branch kit

Fintherm® T-branch kit is designed for the assembly of a branch at any place on an existing pipeline, after removal of insulation from an existing pipe or for making an atypical branch. The mounting branch is designed for welding with a plastic welding extruder. In the event when tapping is required, your order for the branch kit must also include the tapping valve – see chapter 5.8

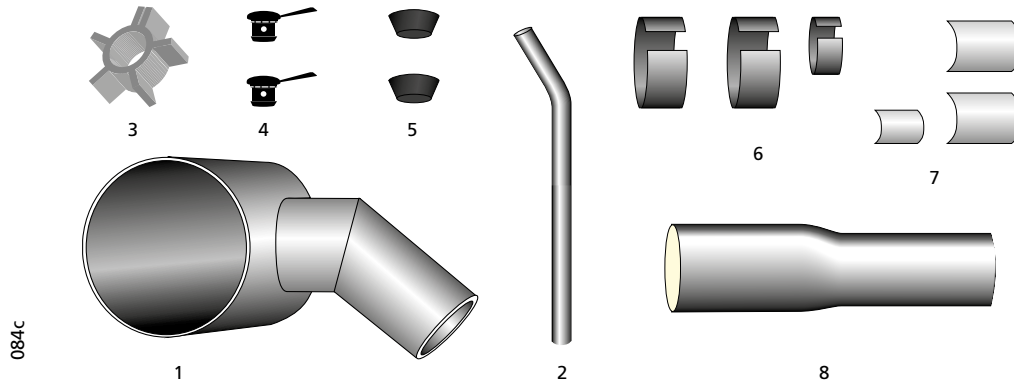

The branch kit includes:

1. Saddle	1 piece	6. Narrow shrink sleeves	2+1 pieces*
2. Branch carrying pipe	1 piece	7. Closing patches	2+1 pieces*
3. Centring ring	1 piece	8. Reduction piece	1 piece*
4. Venting plugs	2 pieces	PUR components	
5. Welding plugs	2 pieces	(quantity according to the dimensions)	

* Items so marked are included in the branch kit only if the branching off pipe is in the first insulation class (due to larger tapping valves and lesser insulation thickness it is typical to use a casing branch pipe with a larger diameter, which must be then reduced).

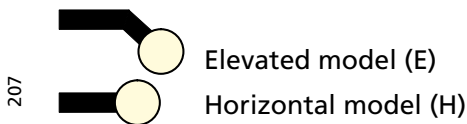

If the branch is in the first insulation class, pull the diameter reducer on the end of the branch and secure it in position with shrink bands and a closing strap.

Code: Fintherm® Standard T-kit (insulation class - DN of the main piping/casing diameter)
 x (insulation class - DN of the branch/casing diameter) (model E or H)
 Ex.: FTS T-kit 1-DN100/200 x 1-DN25/90 E

Fintherm® Standard

1.6 Reducers

1.6.1 Prefabricated reducers

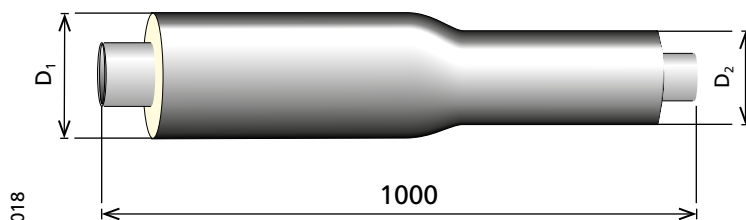

Pre-insulated reducers can be supplied in the following casing pipe sizes:

$\begin{matrix} D_1 \\ \backslash \\ D_2 \end{matrix}$	110	125	140	160	180	200	225	250	280	315	355	400	450	500	560	630	710
90	<input type="checkbox"/>	<input type="checkbox"/>	<input type="checkbox"/>	<input type="checkbox"/>													
110		<input type="checkbox"/>	<input type="checkbox"/>	<input type="checkbox"/>	<input type="checkbox"/>												
125			<input type="checkbox"/>	<input type="checkbox"/>	<input type="checkbox"/>	<input type="checkbox"/>											
140				<input type="checkbox"/>	<input type="checkbox"/>	<input type="checkbox"/>	<input type="checkbox"/>										
160					<input type="checkbox"/>	<input type="checkbox"/>	<input type="checkbox"/>	<input type="checkbox"/>									
180						<input type="checkbox"/>	<input type="checkbox"/>	<input type="checkbox"/>	<input type="checkbox"/>								
200							<input type="checkbox"/>	<input type="checkbox"/>	<input type="checkbox"/>	<input type="checkbox"/>							
225								<input type="checkbox"/>	<input type="checkbox"/>	<input type="checkbox"/>	<input type="checkbox"/>						
250									<input type="checkbox"/>	<input type="checkbox"/>	<input type="checkbox"/>	<input type="checkbox"/>					
280										<input type="checkbox"/>	<input type="checkbox"/>	<input type="checkbox"/>	<input type="checkbox"/>				
315											<input type="checkbox"/>	<input type="checkbox"/>	<input type="checkbox"/>				
355												<input type="checkbox"/>	<input type="checkbox"/>	<input type="checkbox"/>			
400													<input type="checkbox"/>	<input type="checkbox"/>	<input type="checkbox"/>		
450														<input type="checkbox"/>	<input type="checkbox"/>	<input type="checkbox"/>	
500															<input type="checkbox"/>	<input type="checkbox"/>	<input type="checkbox"/>
560																<input type="checkbox"/>	<input type="checkbox"/>
630																	<input type="checkbox"/>

For other sizes, different technical solutions are offered.

Important note:

For hydraulic and strength reasons, we recommend using reducers with a diameter change of no more than two of DN degrees. If a larger DN change is necessary, use more reducers arranged in succession in accordance with the design documentation.

When ordering, please specify the DN dimensions and insulation class.

Code: Fintherm® Standard RED (insulation class - larger DN/casing diameter)
 x (insulation class - smaller DN/casing diameter)
 Ex.: FTS RED 1-DN100/200 x 1-DN80/160

Fintherm® Standard

1.6.2 Modular reduction kits (reduced joint)

Fintherm® Standard reduction kits (for installation in joints) are offered as standard shrinkable version. The advantage of the shrinkable modular reduction kit is that there are two independent systems for sealing a reduced joint.

The kit comprises:

- | | |
|---|----------|
| 1. PE shrinkable casing reducer | 1 piece |
| 2. Steel reducer | 1 piece |
| 3. Narrow shrink sleeve | 2 pieces |
| 4. Closing patch | 2 pieces |
| 5. Venting plug | 2 pieces |
| 6. Welding plug | 2 pieces |
| 7. Electrical wire support | 2 pieces |
| 8. Electrical wire connector | 2 pieces |
| 9. Sealing tape | 1 piece |
| - PUR components (quantity according to the size) | |

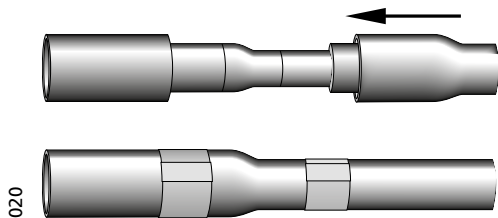
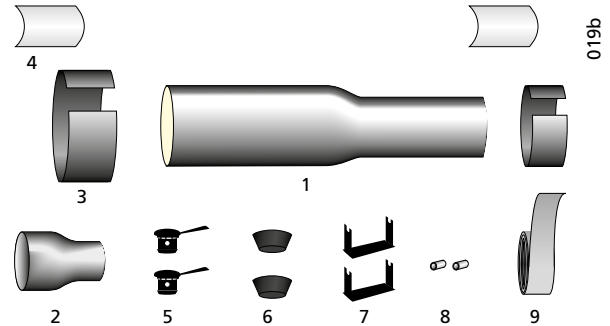

The PE casing reducer is placed over the smaller casing pipe prior to welding of the steel reducer.

The subsequent installation procedure of the shrinkable modular reduction kit is similar to the installation procedure for the DSJ double-sealed shrinkable joint.

Important note:

For hydraulic and strength reasons, we recommend using reducers with a diameter change of no more than two of DN degrees. If a larger DN change is necessary, use more reducers arranged in succession in accordance with the design documentation.

Code: Fintherm® Standard DSJ-SRK (PE larger casing diameter/smaller casing diameter)

Steel reducer (larger DN/smaller DN)

Ex.: FTS DSJ-SRK PE160/140

Steel reducer DN80/DN65

Fintherm® Standard

1.7 Anchors

1.7.1 Straight anchors

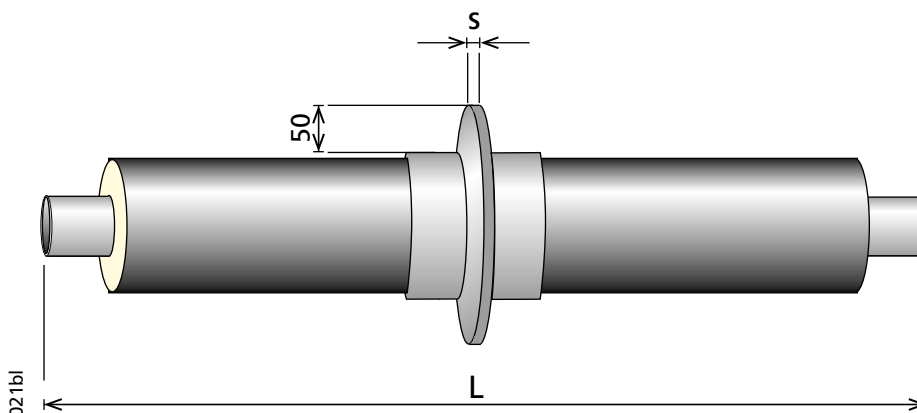

DN	L (m)	s (mm)	Insulation class 1	Insulation class 2	Insulation class 3
			S (cm ²)	S (cm ²)	S (cm ²)
25	2	16	235	267	290
32	2	16	267	290	314
40	2	16	267	290	314
50	2	16	290	314	345
65	3	16	314	345	376
80	3	16	345	376	408
100	3	20	408	447	486
125	3	20	447	486	534
150	3	20	486	534	589
200	3	25	589	651	722
250	3	25	722	801	879
300	3	35	801	879	973
350	3	35	879	973	1083
400	3	35	973	1083	1209
450	3	40	1083	1209	1350
500	3	40	1209	1350	1507
600	3	40	1350	1507	1665

Fintherm® Standard anchors are designed to be embedded into a reinforced concrete block. It may also be attached to the supporting structure (e.g. welded to a steel structure).

S = area of anchor plate outside the casing
s = anchor plate thickness

Code: Fintherm® Standard (insulation class) AP (DN/casing diameter)
Ex.: FTS 1 AP DN80/160

Fintherm® Standard

1.7.2 Elbow anchors

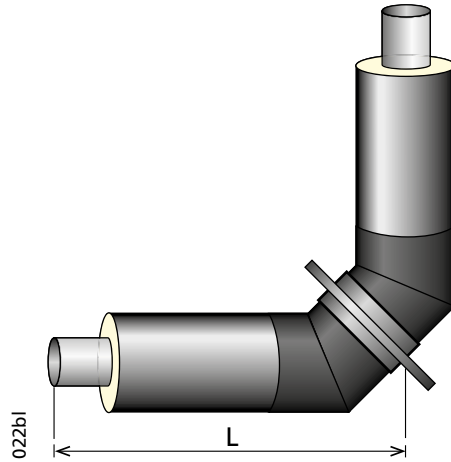

DN	L (mm)	R (mm)
25	1200	112
32	1200	130
40	1200	150
50	1200	190
65	1200	232
80	1200	274
100	1200	340
125	1200	190
150	1200	229
200	1200	305
250	1200	381
300	1200	457
350	1200	533
400	1200	610
450	1200	686
500	1400	762
600	1500	914

Fintherm® Standard elbow anchors are manufactured with both arms of equal length. The dimensions of the anchor plates are similar to those of the anchors (see Chapter 1.2.6).

Bending Radius R:

DN 25 - DN 100: $R = 3 D$

DN 125 - DN 600: $R = 1,5 D$

Code: **Fintherm® Standard** (insulation class)

EA (DN/casing diameter) (elbow angle)

Ex.: FTS 1 EA DN65/140 90°

Fintherm® Standard

1.8 One time compensators

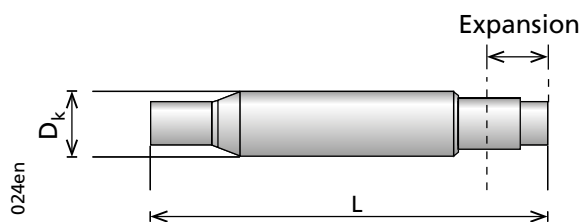

One time compensators are used to achieve and maintain continuous pipe prestressing, which reduces the axial stress particularly in long straight sections of piping. One time compensators are installed especially where the stress generated by thermal expansion cannot be compensated in any other way (e.g. natural bends of the line, "U" expansion pieces, etc.).

DN (mm)	L (mm)	Expansion (mm) PN 25	D _k (mm)
40	275	50	73,0
50	275	50	86,0
65	335	70	106,0
80	345	70	122,0
100	390	80	139,7
125	400	80	168,3
150	475	100	193,7
200	515	120	268,0
250	515	120	323,9
300	660	140	355,6
350	650	140	406,4
400	650	140	457,2
450	660	150	508,0
500	660	150	560,0
600	690	150	675,0

Please note:

- It is recommended to consult the selection, location and suitability of the use of one time compensators with the representatives of FINTHERM a.s.
- When installing the compensator, observe the technological process specified in the Installation Manual of FINTHERM a.s. available at www.fintherm.cz.
- The compensator position is secured with welds for transport. These welds however, are not sufficient for pressure testing and subsequent installation. Therefore, the compensator must be secured against expansion with additional welds.
- When foaming the space of the compensator, the temperature must not exceed 40°C.

Technical data:

- Material: AISI 321 / W-Nr. 1.4541
- Nominal pressure: 2,5 MPa

Code: Fintherm® Standard OB (dimension) (nominal pressure) Exp (expansion)

Ex.: FTS 1 OB DN100 PN 25 Exp 80

Fintherm® Standard

1.9 Shut-off valves

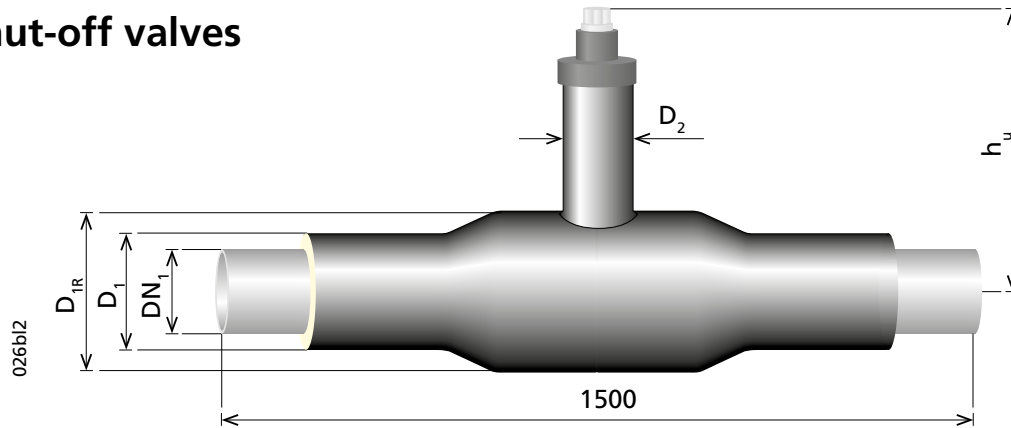

FINTHERM shut-off valves DN 25 - DN 600 are manufactured only as a long spindle ball valves. We deliver a reduced flow-rate profile of the valve closing by default.

DN ₁	D ₁ (mm)	D _{1R} (mm)	h _u (mm)	D ₂ (mm)
DN 25	90	110	480	110
DN 32	110	125	485	110
DN 40	110	125	495	110
DN 50	125	140	500	110
DN 65	140	160	504	110
DN 80	160	200	515	110
DN 100	200	225	525	140
DN 125	225	280	545	140
DN 150	250	315	565	140
DN 200	315	400	585	140
DN 250	400	500	560	200

Valve Material:

- Valve body: carbon steel P235 GH
- Ball: SIS 2333, AISI 304 (stainless steel)
- Gasket: PTFE, carbon reinforced
- Upper part of spindle: SIS 2333, AISI304 - stainless steel

h_u = maximum length from axis of carrier pipe to the upper end of spindle

Important note:

When the shut-off valve is being welded into the pipeline, the valve must be in the open position so as not to damage its seal.

Data in the table applies for the first class of insulation only. For larger dimensions and other insulation classes, technical parameters are available upon request.

Shut-off valves can be supplied in various sizes and designs according to the customer's requirements.

Based on the customer's requirements, valves are controlled either manually with a T-key (DN 25 - DN 80 = size 19 and DN 100 - DN 150 = size 27), through a manual moment multiplier, or with a gearbox (for dimensions of DN 200 and above).

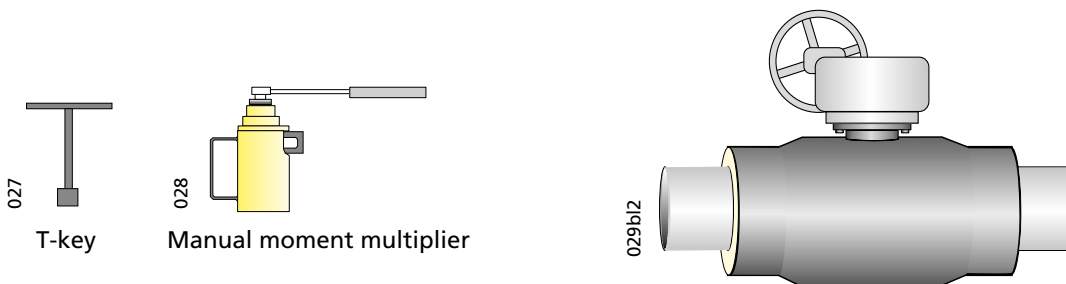

Code: Fintherm® Standard (insulating class)
 SV (piping DN/casing diameter) (rated pressure)
 Ex.: FTS 1 SV DN200/315 PN25

Fintherm® Standard

1.10 Drain/Air relief valves

1.10.1 Suction modification

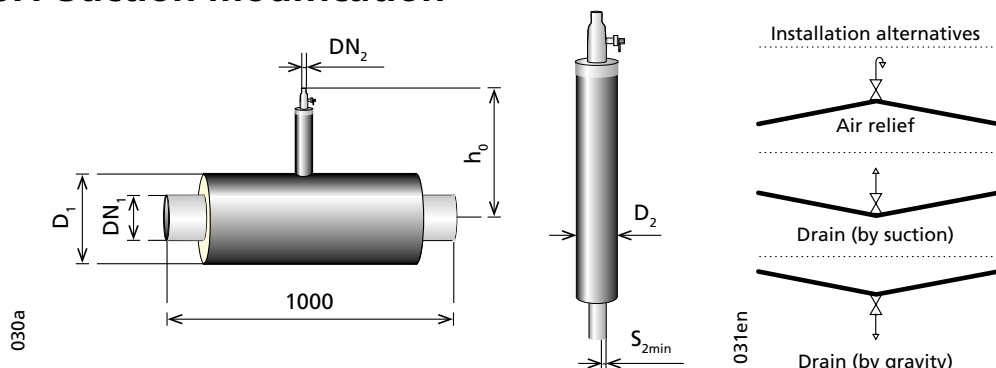

The drain and air relief parts of the valves are produced with an increased wall thickness compared to the thickness of standard pipes.

Valve Material:

- Service pipe: carbon steel P235 GH
- Ball and body: SIS 2333, AISI 304 (stainless steel)
- Gasket: PTFE, carbon reinforced

A drain valve with a different height of the bleeding or discharge arm or a drain valve of a bigger size, height arm length can be supplied upon request or insulation class.

DN ₂	D ₂	s _{2min} (mm)
25	110	7,1
32	125	7,1
40	140	5,6
50	160	7,1

DN ₁	D ₁ (mm)	h ₀ (mm)
DN 25	90	430
DN 32	110	430
DN 40	110	435
DN 50	125	440
DN 65	140	450
DN 80	160	455
DN 100	200	470
DN 125	225	480
DN 150	250	495
DN 200	315	520
DN 250	400	545

Values in the table only apply for 1st class of insulation (DN) and only include dimensions DN 25, 32 and 40 for drain/air relief. Values given for larger dimensions and higher insulation classes available upon request.

Code: Fintherm® Standard (insulation class) D/A-V
(DN pipe dimension/casing diameter)/(DN valve dimension)
Ex.: FTS 1 D/A-V DN100/200 x DN25

1.10.2 Gravitation model – kit

The drain and air relief parts of the valves are produced with an increased wall thickness compared to the thickness of standard pipes.

The dimensions correspond to the elevated T-branch (1.2.4.2) with a welded on shut-off valve.

Valve Material:

- Service pipe: carbon steel P 235 GH
- Ball and body: SIS 2333, AISI 304 (stainless steel)
- Gasket: PTFE, reinforced with carbon

A drain valve with a different length of the bleeding or discharge arm or a drain valve of a bigger size can be supplied upon request or insulation class.

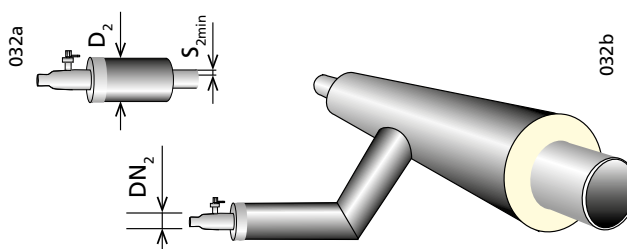

D₂ = valve casing diameter
s₂ = pipe wall thickness

The values are meant for insulation class 1.

DN ₂	D ₂	s _{2min} (mm)
25	110	7,1
32	125	7,1
40	140	5,6
50	160	7,1

Code: Fintherm® Standard (insulation class)
D-V (DN pipe dimension/casing diameter)/(DN air/drain valve dimension)
Ex.: FTS 1 D-V DN200/315 x DN32

Fintherm® Standard

1.10.3 Suction model – kit

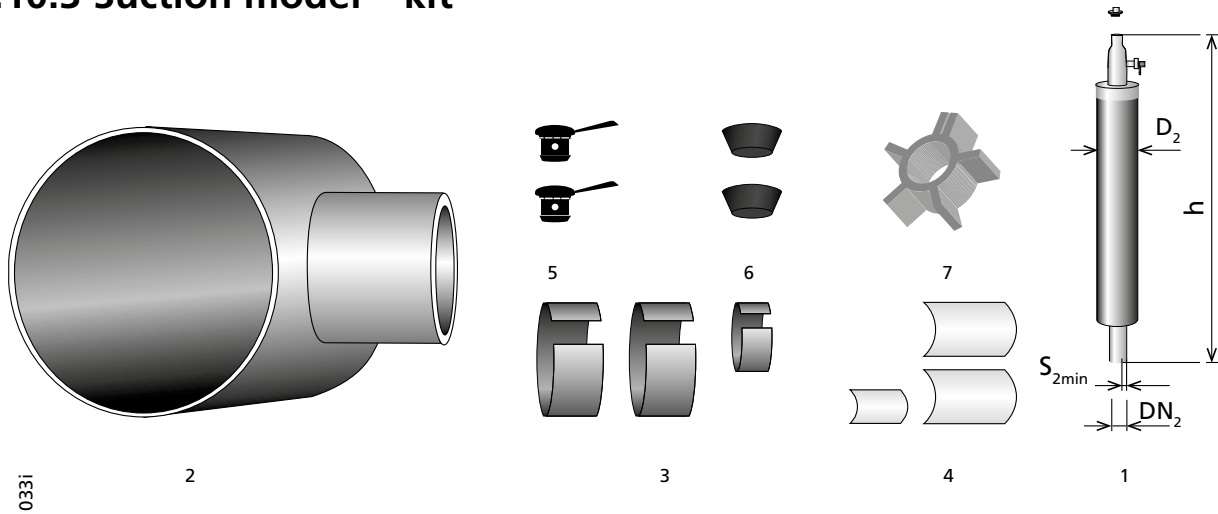

The kit comprises:

- | | |
|--|------------|
| 1. Valve | 1 piece |
| 2. Saddle | 1 piece |
| 3. Narrow shrinks sleeves | 2+1 pieces |
| 4. Closing patches | 2+1 pieces |
| 5. Venting plugs | 2 pieces |
| 6. Welding plugs | 2 pieces |
| 7. Centring ring | 1 piece |
| - PUR components
(quantity according to the dimensions) | |

The values are meant for insulation class 1.

DN ₂	D ₂	S _{2min} (mm)	h (mm)
25	110	7,1	410
32	125	7,1	410
40	140	5,6	410
50	160	7,1	500

D₂ = valve casing diameter
s₂ = pipe wall thickness

The drain / air relief valve kit is designed for on-site assembly. The drain and air relief parts of the valves are produced with an increased wall thickness compared to the thickness of standard pipes. Drain valves with a different wall-thickness, larger diameter, or different air relief or drain arm length can be supplied upon request. For installation, see 6.7.

Valve Material:

- Service pipe: carbon steel P235 GH
- Ball and body: SIS 2333, AISI 304 - stainless steel
- Gasket: PTFE, carbon reinforced

Code: Fintherm® Standard (insulation class) D/A-V KIT (DN pipe dimension/casing diameter)

/ (DN air/drain valve dimension)

Ex.: FTS 1 D/A-V KIT DN80/160 x DN20

1.10.4 Welded end valves

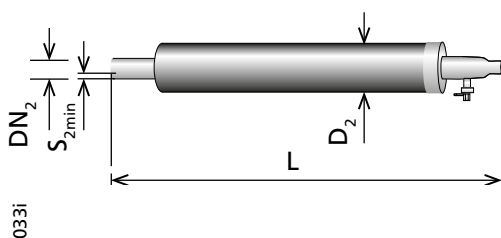

An air relief valve or drain valve welded on a pipe separately is available upon request. For dimensions and materials see Chapter 1.2.10.3.

Code: Fintherm® Standard (insulation class)
D/A-S (DN pipe dimension)/(casing diameter) (L= length)

Ex.: FTS 1 D/A-S DN50/125 L=500 mm

Fintherm® Standard

1.11 Combination valves

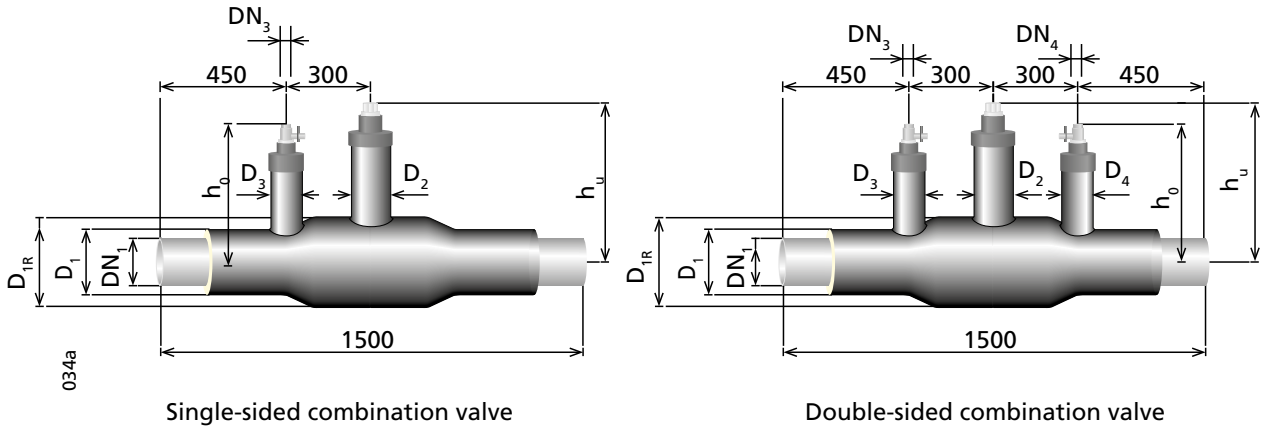

Fintherm® Standard combination valves are produced as ball valves with either single-sided or double-sided drain / air relief valves.

Combined drain / air relief valves in the DN 25 to 50 range are standard. We deliver a reduced flow-rate profile of the valve closing by default.

Stainless steel the drain and air relief parts of the valves are produced with an increased wall thickness compared to the thickness of standard pipes, for dimension and materials see Chapter 1.2.10.1.

DN ₁	D ₁ (mm)	D _{1R} (mm)	h _u (mm)	h ₀ (mm)	D ₂ (mm)
DN 25	90	110	480	450	110
DN 32	110	125	485	415	110
DN 40	110	125	495	405	110
DN 50	125	140	500	425	110
DN 65	140	160	504	430	110
DN 80	160	200	515	444	110
DN 100	200	225	525	458	140
DN 125	225	280	545	471	140
DN 150	250	315	565	488	140
DN 200	315	400	585	514	140
DN 250	400	500	560	540	200

DN ₃	D ₃	S _{3min}
DN ₄	D ₄	S _{4min}
DN 25	110	7,1
DN 32	125	7,1
DN 40	140	5,6
DN 50	160	7,1

Valve Material:

- Valve body: carbon steel P235 GH
- Ball and body: SIS 2333, AISI 304 - stainless steel
- Gasket: PTFE, carbon reinforced
- Upper part of spindle: SIS 2333, AISI 304 - stainless steel

Values in the table only apply for 1st class of insulation (DN) and only include dimensions DN 25, 32 and 40 for drain/air relief. Values given for larger dimensions and higher insulation classes available upon request.

Possible combinations of use:

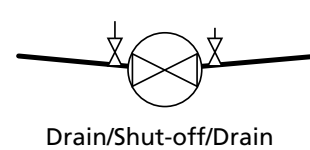
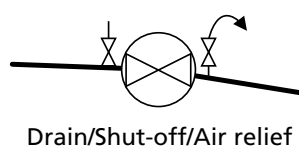
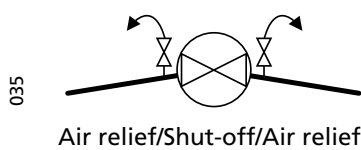

Fintherm® Standard

Important note:

When the combined valve is being welded into the pipeline, the valve must be in the open position so as not to damage its seal.

Code:

Fintherm® Standard (insulation class) COMBI V (DN shut-off valve dimension/casing diameter)
x (one-sided: DN drain / air relief valve dimension)

Ex.: FTS 1 COMBI V DN100/200 x DN32

or

Fintherm® Standard (insulation class) COMBI V (DN shut-off valve dimension/casing diameter)
2x (double-sided: DN drain / air relief valve dimensions, DN drain / air relief valve dimensions)

Ex.: FTS 1 COMBI V DN80/160 2x DN32

2 Fintherm[®] Standard Spiro

2 Fintherm[®] Standard Spiro

2.1 Technical specification

2.2 Pipes

2.3 Elbows

2.4 Other pre-insulated elements

Fintherm® Standard Spiro

2.1 Technical Specification

2.1.1 Steel carrier pipe

The steel piping used in the Fintherm® Standard Spiro Casing system is made of longitudinally or helically welded pipes in compliance with the EN10217-1, EN10217-2, and EN10217-5 standards or, upon request, of seamless pipes in accordance with EN10216-2.

Material:	P 235 GH, P 265 GH
Certification:	EN 10204 - 3.1
Bevelling:	DIN 2559/22
Lengths:	DN 25: L = 6 m
	DN 32 - DN 80: L = 6 m, 12 m
	DN 100 - DN 700: L = 6 m, 12 m, 16 m
Density:	7850 kg/m ³
Modulus of elasticity:	2,06 · 10 ⁵ N/mm ²
Yield strength:	235 N/mm ²
Tensile strength:	350 N/mm ²
Heat conductivity:	46 - 54,5 W/mK
Thermal expansion coefficient:	1,2 · 10 ⁻⁵ K ⁻¹

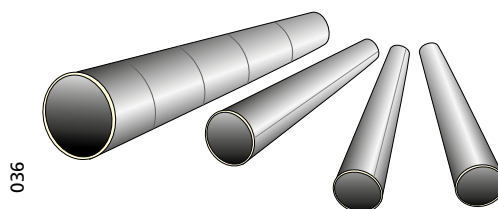

2.1.2 Rigid PUR insulation

Rigid polyurethane foam (PUR) is produced by mixing polyalcohols (polyols) containing additives and isocyanates (MDI). The mixture is injected into pipes using a high-pressure foaming technique. Cyclopentane or a gas of similar properties is used as the blowing agent. The PUR foam used in the Fintherm® Standard Spiro Casing system is CFC-free and meets the stringent requirements of European Standard EN 253.

Average cell size:	≤ 0,5 mm
Closed cell content:	≥ 88 %
Core density:	≥ 60 kg/m ³
Compressive strength:	≥ 0,3 MPa
Water absorption:	≤ 10 %
Shear strength:	≥ 0,12 MPa
Thermal conductivity (+ 50°C):	0,026 W/mK

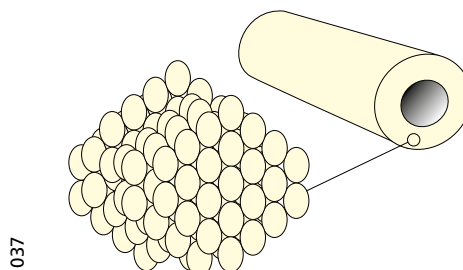

2.1.3 Spiro casing pipe

Spiro casing pipes are made of spiral overlaid steel zinc-coated sheets.

Other material is available upon request.

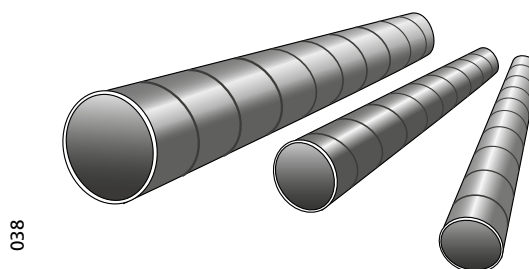

Fintherm® Standard Spiro

2.2.1 Pipes

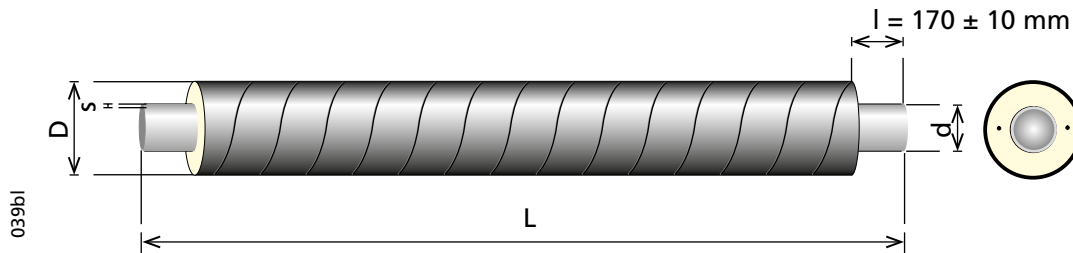

Insulation class 1

DN	d . s (mm)	D (mm)	L (m)	Weight (kg/m)	Insulation thickness (mm)	Water volume (l/m)
50	60,3 . 2,9	125	6, 12	6,9	32	2,33
65	76,1 . 2,9	140	6, 12	8,4	31	3,88
80	88,9 . 3,2	160	6, 12	10,5	35	5,35
100	114,3 . 3,6	200	6, 12, 16	14,8	42	9,01
125	139,7 . 3,6	225	6, 12, 16	17,7	42	13,79
150	168,3 . 4,0	250	6, 12, 16	22,4	40	20,18
200	219,1 . 4,5	315	6, 12, 16	31,9	47	34,67
250	273,0 . 5,0	400	6, 12, 16	47,1	63	54,30
300	323,9 . 5,6	450	6, 12, 16	59,8	62	76,80
350	355,6 . 5,6	500	6, 12, 16	66,9	71	93,20
400	406,4 . 6,3	560	6, 12, 16	83,5	76	121,80
450	457,0 . 6,3	630	6, 12	95,0	86	155,10
500	508,0 . 6,3	710	6, 12	107,8	100	192,80
600	610,0 . 7,1	800	6, 12	142,7	94	276,70

A standard casing pipe is made of spiral overlaid steel zinc-coated sheets.
Pipes are available in other sizes upon special request.

Code: Fintherm® Standard Spiro (insulation class) P (DN/casing diameter) Spiro (length)
Ex.: FTSS 1 P DN100/200 Spiro 12m

Fintherm® Standard Spiro

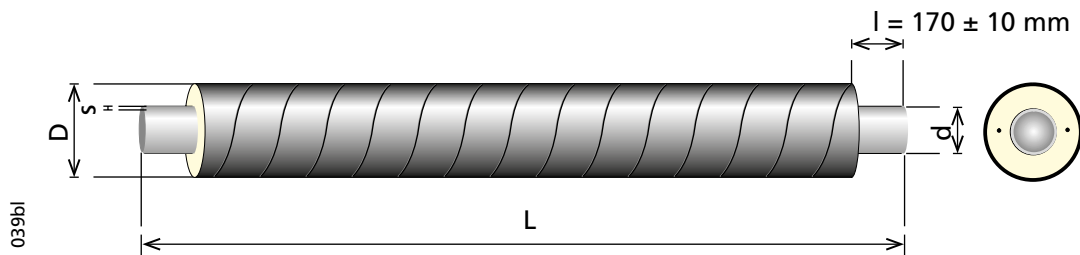

Insulation class 2

DN	d . s (mm)	D (mm)	L (m)	Weight (kg/m)	Insulation thickness (mm)	Water volume (l/m)
32	42,4 . 2,6	125	6, 12	5,4	41	1,09
40	48,3 . 2,6	125	6, 12	5,8	38	1,46
50	60,3 . 2,9	140	6, 12	7,3	39	2,33
65	76,1 . 2,9	160	6, 12	9,0	41	3,88
80	88,9 . 3,2	180	6, 12	11,2	45	5,35
100	114,3 . 3,6	225	6, 12, 16	15,8	55	9,01
125	139,7 . 3,6	250	6, 12, 16	18,8	55	13,79
150	168,3 . 4,0	280	6, 12, 16	23,9	55	20,18
200	219,1 . 4,5	355	6, 12, 16	33,7	67	34,67
250	273,0 . 5,0	450	6, 12, 16	50,7	88	54,30
300	323,9 . 5,6	500	6, 12, 16	63,8	87	76,80
350	355,6 . 5,6	560	6, 12, 16	72,0	101	93,20
400	406,4 . 6,3	630	6, 12, 16	93,6	111	121,80
450	457,0 . 6,3	710	6, 12	102,4	126	155,10
500	508,0 . 6,3	800	6, 12	120,9	145	192,80

A standard casing pipe is made of spiral overlaid steel zinc-coated sheets.
Pipes are available in other sizes upon special request.

Code: Fintherm® Standard Spiro (insulation class) P (DN/casing diameter) Spiro (length)
Ex.: FTSS 2 P DN100/225 Spiro 12m

Fintherm® Standard Spiro

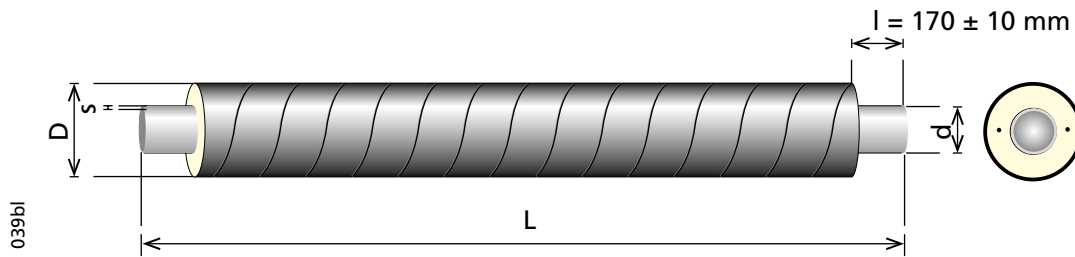

Insulation class 3

DN	d . s (mm)	D (mm)	L (m)	Weight (kg/m)	Insulation thickness (mm)	Water volume (l/m)
25	33,7 . 2,6	125	6	4,9	45	0,64
32	42,4 . 2,6	140	6, 12	5,9	48	1,09
40	48,3 . 2,6	140	6, 12	6,2	45	1,46
50	60,3 . 2,9	160	6, 12	8,0	49	2,33
65	76,1 . 2,9	180	6, 12	9,7	51	3,88
80	88,9 . 3,2	200	6, 12	12,0	55	5,35
100	114,3 . 3,6	250	6, 12, 16	16,9	67	9,01
125	139,7 . 3,6	280	6, 12, 16	20,3	70	13,79
150	168,3 . 4,0	315	6, 12, 16	25,4	73	20,18
200	219,1 . 4,5	400	6, 12, 16	39,4	90	34,67
250	273,0 . 5,0	500	6, 12, 16	54,6	113	54,30
300	323,9 . 5,6	560	6, 12, 16	68,8	117	76,80
350	355,6 . 5,6	630	6, 12	82,1	136	93,20
400	406,4 . 6,3	710	6, 12	96,8	151	121,80
450	457,0 . 6,3	800	6, 12	115,5	171	155,10

A standard casing pipe is made of spiral overlaid steel zinc-coated sheets.
Pipes are available in other sizes upon special request.

Code: Fintherm® Standard Spiro (insulation class) P (DN/casing diameter) Spiro (length)
Ex.: FTSS 3 P DN100/250 Spiro 12m

Fintherm® Standard Spiro

2.3 Elbows

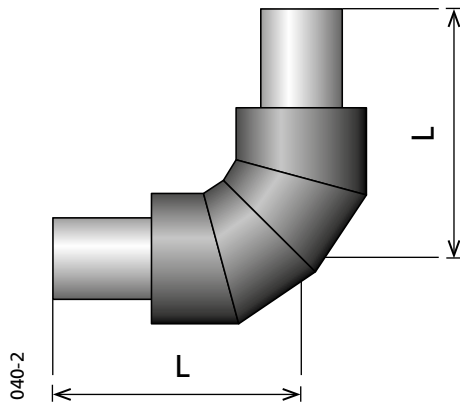

Prefabricated insulated elbows are made in standard 90° angle.

For other sizes, insulation class, specific angle or bending radius R, please contact the FINTHERM® technical department.

Lengths of the non-insulated pipe ends for small sizes of up to DN 50 are shorter than the lengths of straight pipes.

Code: Fintherm® Standard Spiro
(insulation class) E (DN/casing diameter)
(angle) Spiro
Ex.: FTSS 1 E DN40/110 90° Spiro

The table shows the dimensions for a 90° angle in the first and second insulation classes.

DN	R (mm)	Insulation class 1	Insulation class 1
		L (mm)	L (mm)
32	130		350
40	150		370
50	190	380	390
65	232	440	450
80	274	480	485
100	340	545	550
125	190	435	440
150	229	460	470
200	305	535	540
250	381	605	610
300	457	675	680
350	533	760	775
400	610	845	850
450	686	920	940
500	762	1030	1035

2.4 Other pre-insulated elements

We can supply pre-insulated valves, branches, reducers, and other fittings covered with Spiro casing upon request. Basic information about the Fintherm® Standard system can be used, while the actual dimensions and manufacturing options must be discussed in advance with the FINTHERM® technical department.

3 Fintherm® Twins

3 Fintherm® Twins

3.1 Technical specification

3.2 Pipes

3.3 Elbows

3.4 T-branches

3.5 Change-pieces

3.6 Anchors

3.7 Shut-off valves

3.8 Drain/Air relief valves

3.1 Technical specification

3.1.1 Steel carrier pipe

The steel piping used in the Fintherm® Twins system is made of longitudinally or helically welded pipes in compliance with EN10217-1, EN10217-2, and EN10217-5 standards or, upon request, of seamless pipes in accordance with EN10216-2.

Material:	P 235 GH, P 265 GH	
Certification:	EN 10204 - 3.1	
Bevelling:	DIN 2559/22, ISO 6761	
Lengths:	DN 25:	L = 6 m
	DN 32 - DN 80:	L = 6 m, 12 m
	DN 100 - DN 250:	L = 6 m, 12 m, 16 m
Density:	7850 kg/m ³	
Modulus of elasticity:	2,06 · 10 ⁵ N/mm ²	
Yield strength:	235 N/mm ²	
Tensile strength:	350 N/mm ²	
Heat conductivity:	46 - 54,5 W/mK	
Thermal expansion coefficient:	1,2 · 10 ⁻⁵ K ⁻¹	

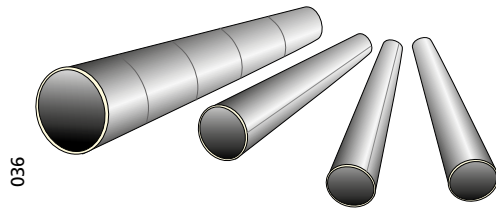

3.1.2 Rigid PUR insulation

Rigid polyurethane foam (PUR) is produced by mixing polyalcohols (polyols) containing additives and isocyanates (MDI). The mixture is injected into pipes using a high-pressure foaming technique. Cyclopentane or a gas of similar properties is used as the blowing agent. The PUR foam used in the Fintherm® Twins system is CFC-free and meets the stringent requirements of European Standard EN 253.

Average cell size:	≤ 0,5 mm
Closed cell content:	≥ 88 %
Core density:	≥ 60 kg/m ³
Compressive strength:	≥ 0,3 MPa
Water absorption:	≤ 10 %
Shear strength:	≥ 0,12 MPa
Thermal conductivity (+ 50°C):	0,026 W/mK

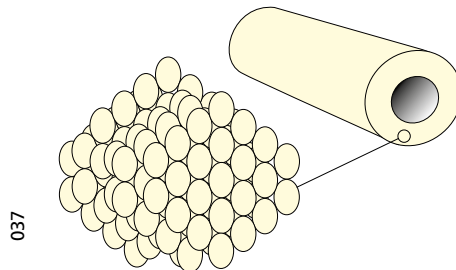

3.1.3 PE-HD casing pipe

Material PE-HD (high-density polyethylene)

Dimensions:	EN 253
Material:	PE-HD
Density (+20°C):	~ 960 kg/m ³
Heat conductivity:	0,43W/mK
Thermal expansion coefficient:	1,8 · 10 ⁻⁴ K ⁻¹
Melt flow index (MFI 190/5):	0,2 to 1,4
Carbon black content:	2,5 ± 0,5 % ASTM D-21603
Elongation at break:	≥ 350% ISO R-292
Impact strength:	≥ 10 mJ/mm ² ISO R-179
Tensile strength:	≥ 17 MPa ISO DIS 572B

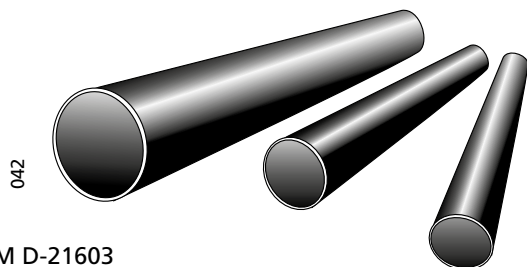

The material is protected against the effects of UV radiation

3.2. Pipes

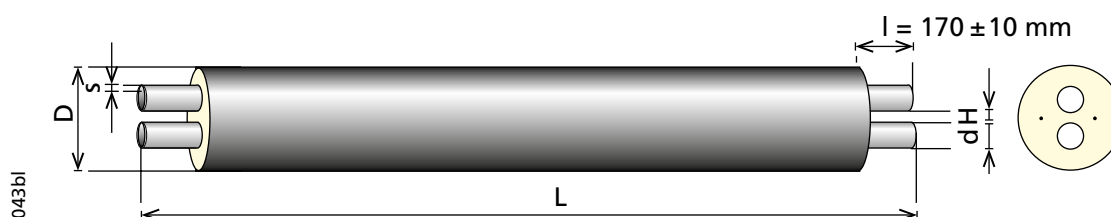

Insulation classes 1 and 2

DN	d . s (mm)	D (mm)			L (m)	H (mm)	Weight (kg/m)		
		Insulation class 1	Insulation class 2	Insulation class 3			Insulation class 1	Insulation class 2	Insulation class 3
25 + 25	33,7 . 2,6	140	160	180	6, 12	19	6,2	6,7	7,4
32 + 32	42,4 . 2,6	160	180	200	6, 12	19	7,7	8,4	9,3
40 + 40	48,3 . 2,6	160	180	200	6, 12	19	8,4	9,1	10
50 + 50	60,3 . 2,9	200	225	250	6, 12	20	11,9	13,1	14,5
65 + 65	76,1 . 2,9	225	250	280	6, 12	20	14,9	16,3	18,1
80 + 80	88,9 . 3,2	250	280	315	6, 12	25	18,7	20,7	22,9
100 + 100	114,3 . 3,6	315	355	400	6, 12	25	27,5	30,7	33
125 + 125	139,7 . 3,6	400	450	500	6, 12, 16	30	36,6	41,4	45,7
150 + 150	168,3 . 4,0	450	500	560	6, 12, 16	40	47,4	54,0	59
200 + 200	219,1 . 4,5	560	630		6, 12, 16	45	71,2	81,7	
250 + 250	273,0 . 5,0	710	800		6, 12, 16	45	102,4	123,1	

Pipes can be manufactured in other lengths and dimensions upon special request.

Code: Fintherm® Twins (insulation class) P (DN/casing diameter) (length)

Ex.: FTT 1 P DN25 + 25/140 12m

3.3 Elbows

3.3.1 Standard elbows

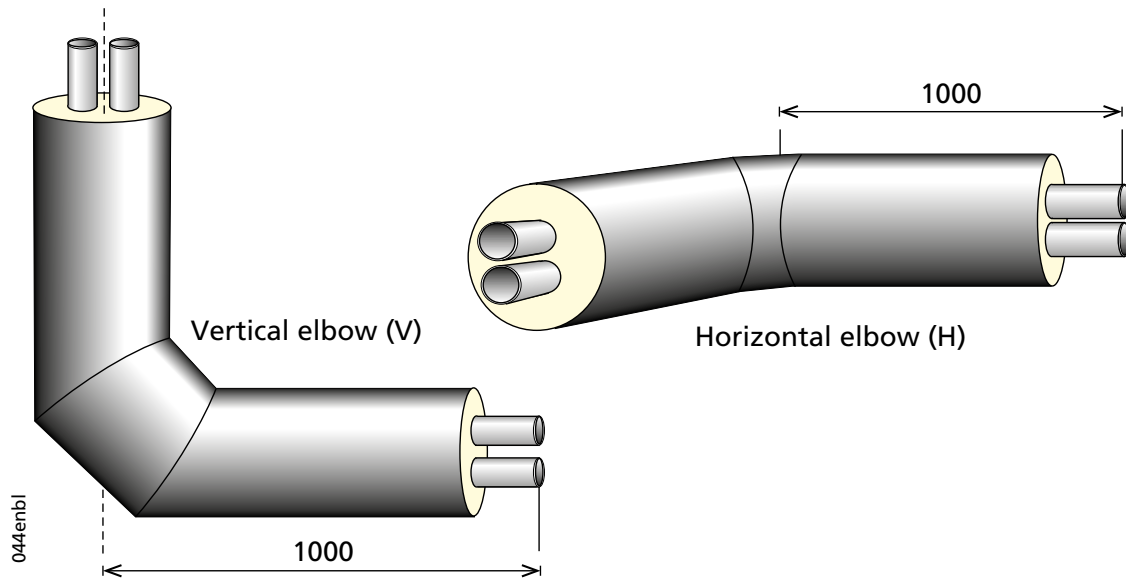

Fintherm® Twins elbows are manufactured in standard angle 90°. Elbows with other angles or manufacturing dimensions can be supplied upon special request.

The elbows are divided into horizontal and vertical types according to the pipe route deviation and standard pipe installation* in the trench:

- a **horizontal elbow** is used when the route turns to the left or the right.
- a **vertical elbow** is used where height difference in the route is encountered.

* The Fintherm® Twins system standard trench installation consists of the supply pipe at the bottom and the return pipe at the top (one pipe above the other).

Code: Fintherm® Twins (insulation class) E (DN/casing diameter) (H=horizontal or V=vertical elbow) (angle)
Ex.: FTT 1 E DN65+65/225 H 45°

3.3.2 Building entry elbows

Building entry elbows are always produced as vertical.

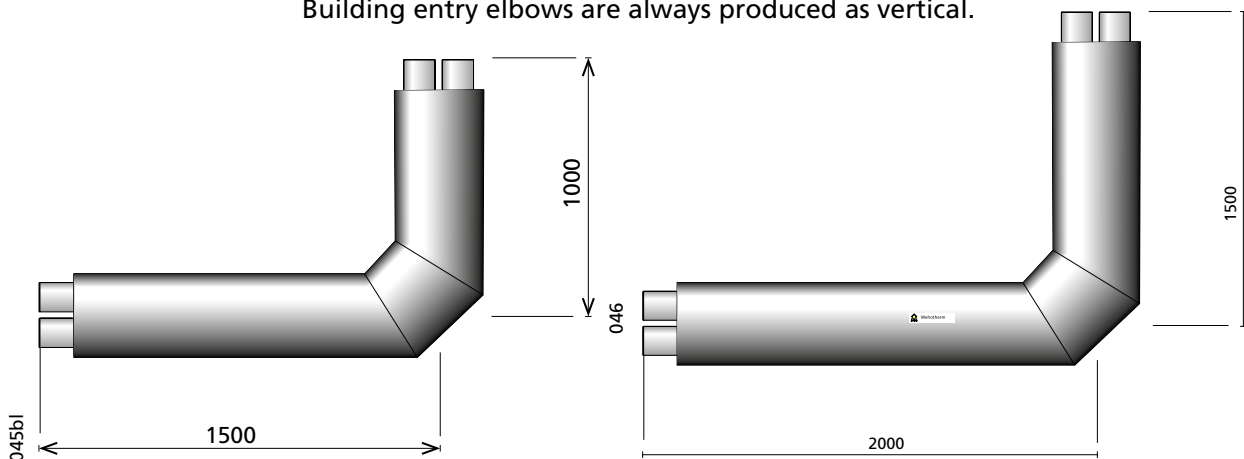

Code: Fintherm® Twins (insulation class) E (DN/casing diameter) (V=vertical) (L=arm longer dimension x arm shorter dimension)

Ex.: FTT 1 E DN65+65/225 L=2,0x1,5m

3.4 T-branches

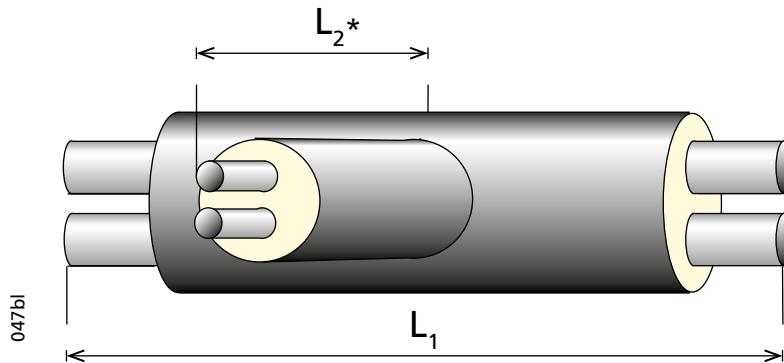

Fintherm® Twins T-branches are manufactured in the following dimensions:

DN₂ 20 - DN₂ 50: L₁ = 1000 mm L₂ = 1000 mm

DN₂ 65 - DN₂ 100: L₁ = 1200 mm L₂ = 1000 mm

DN₂ 125 - DN₂ 200: L₁ = 1500 mm L₂ = 1000 mm

* Dimension L₂ is taken from the centre of the casing pipe of the main route.

Code: Fintherm® Twins T (insulation class-DN main pipe dimension/casing diameter)

X (insulation class- DN branch dimension/casing diameter)

Ex.: FTT T 1-DN80+80/250 x 1-DN32+32/160

Implementation of the steel T-branch from the main route:

1) Necked-Out (Collaring) T-branch Standard T-piece

Standard design using the cold-forming method for the neck and the "V" weld. An advantage of this design is the higher overall strength of the "V" weld compared to a fillet weld, and better shape for the flow of the medium.

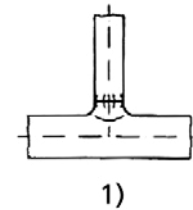

2) Forged T-piece

Welded forged T-pieces according to EN 10253-2 are used if there is a requirement for significantly higher strength or if the branch has the same dimension as the base.

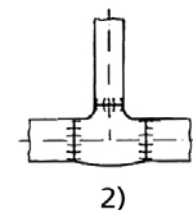

3) Welded tube fitting

In exceptional cases, when it is not technologically possible to use another construction method for the branch, branching with a fillet weld is used. Construction with reinforcement is also possible.

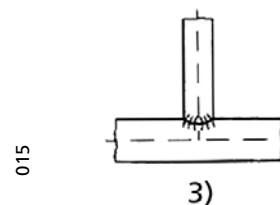

Most branches are also available with larger wall thicknesses for greater strength. It is recommended to consult the specific type and wall thickness with FINTHERM® technical department concerning the wall thickness, or determining such requirement based on static strength calculations according to the specific conditions of the project.

Fintherm® Twins

3.5 Change-pieces

3.5.1 Change-piece Y-model

Change-pieces Y-model are used to transfer from a **Fintherm®** Standard system to a dual **Fintherm®** Standard Twins system or vice versa.

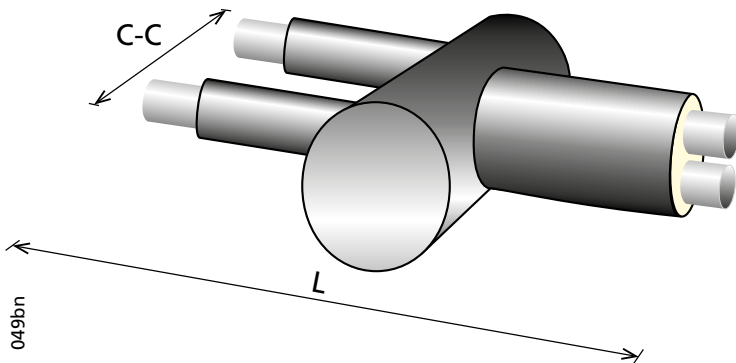

DN	C-C (mm)	L (mm)
25	240	1500
32	240	1500
40	240	1500
50	275	1500
65	275	1500
80	380	1500
100	450	1500
125	450	1500
150	450	1500
200	550	2000

We can supply alternatives to the standard spacing (designated C-C) between the **Fintherm®** Standard pipes upon request.

When ordering, please indicate the direction of the transfer according to the following diagram:

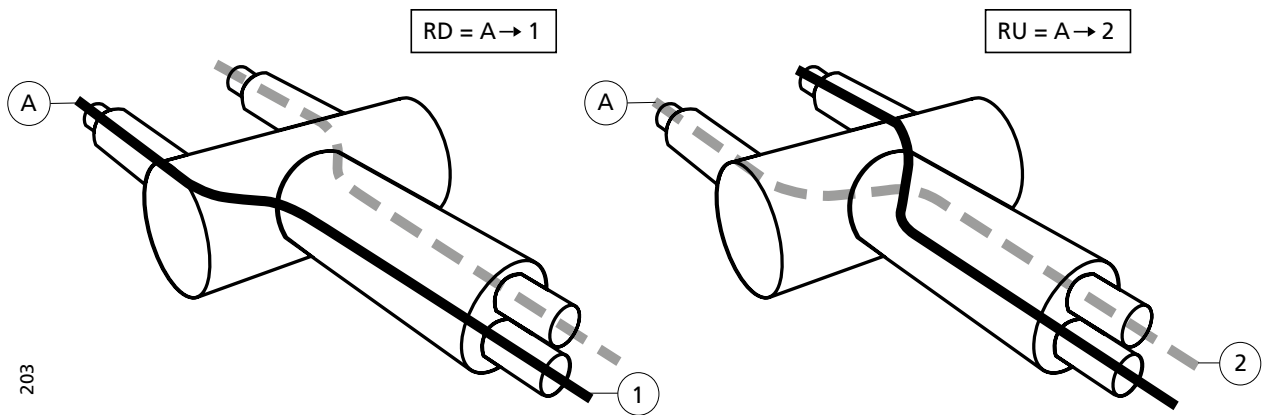

Code: **Fintherm®** Twins CPY (insulation class-DN twin pipe/casing diameter) x (insulation class-DN/casing diameter) (direction of the transition)

Ex.: FTT CPY 1-DN40+40/160 x 1-DN40/110 RD

Important note:

The maximum distance from the change-piece Y-model of the **Fintherm®** Standard system to the nearest compensatory unit type (L, Z, U) must not exceed 12 m, taking into account the effect of expansion.

3.5.2 Change-piece F-model

Change-pieces F-model are used to transfer from **Fintherm®** Standard system to the **Fintherm®** Twins system or vice versa. It is therefore very important to indicate the desired direction of the transfer and the direction of the turn of the change-piece F-model.

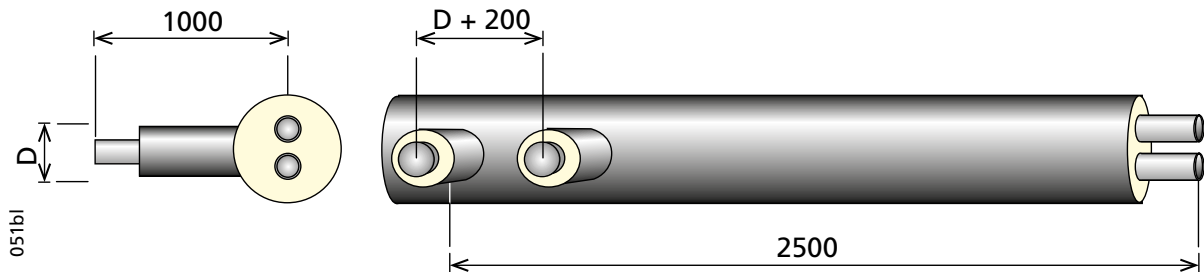

To determine the direction of the transfer and of the turn for a specific route, use the following diagram.

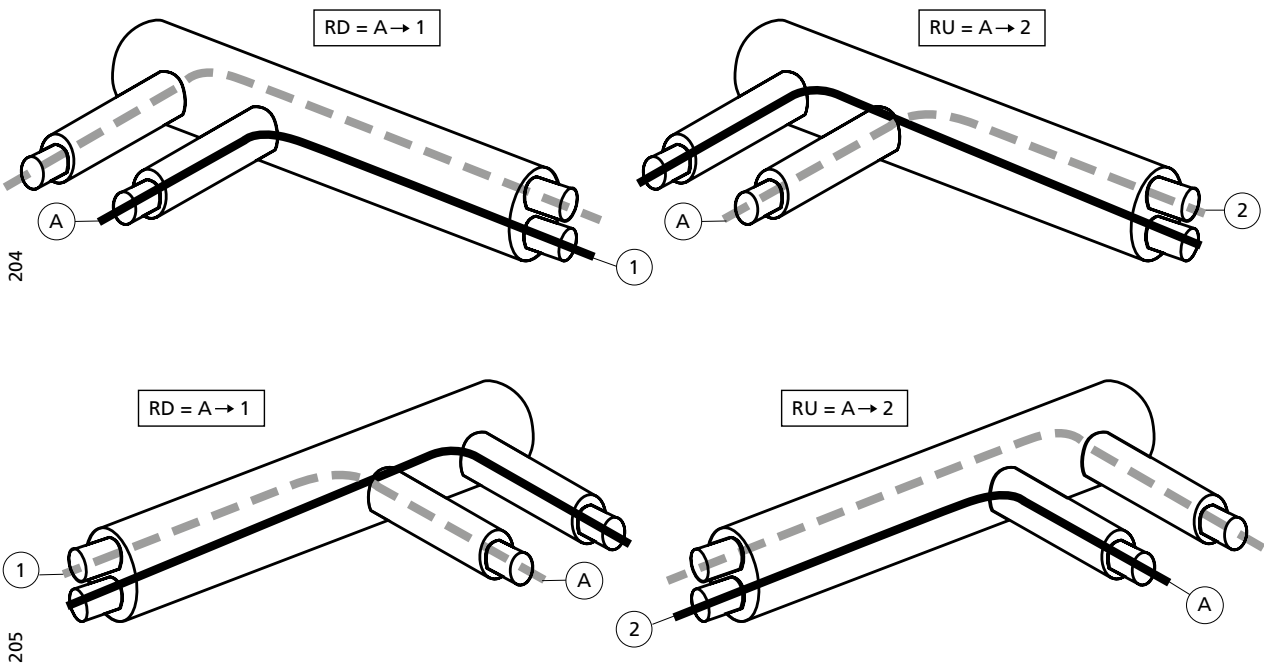

Code: Fintherm® Twins CPF (insulation class-DN twin pipe/casing diameter) x (insulation class-DN/casing diameter) (direction of the transfer)

Ex.: FTT CPF 1-DN40+40/160 x 1-DN40/110 RD

Important note:

The maximum distance from the change-piece F-model of the **Fintherm®** Standard system to the nearest compensatory unit type (L, Z, U) must not exceed 12 m, taking into account the effect of expansion.

3.6 Anchors

3.6.1 Straight anchors

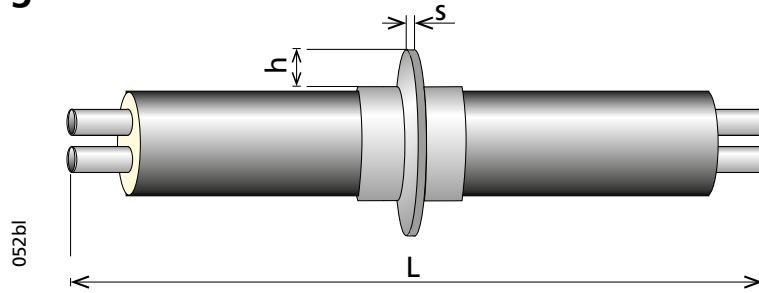

DN	L (m)	s (mm)	S (cm ²)		
			Insulation class 1	Insulation class 2	Insulation class 3
25 + 25	2	20	314	345	376
32 + 32	2	20	345	376	408
40 + 40	2	20	345	376	408
50 + 50	3	20	408	447	486
65 + 65	3	25	447	486	534
80 + 80	3	25	486	534	589
100 + 100	3	25	589	651	722
125 + 125	3	30	722	801	879
150 + 150	3	35	801	879	973
200 + 200	3	35	973	1083	

h = 50 mm, S = area of anchor plate outside the casing
s = anchor plate thickness

The anchors are designed to be embedded into reinforced concrete blocks. It may also be attached to supporting structures (e.g. welded to steel supports).

Code: Fintherm® Twins (insulation class) AP (DN/casing diameter)
Ex.: FTT 1 AP DN80+80/250

3.6.2 Elbow anchors

Fintherm® Twins elbow anchors are manufactured with both arms of equal length. The dimensions of the anchor plates are similar to those of the anchors (see 3.2.6).

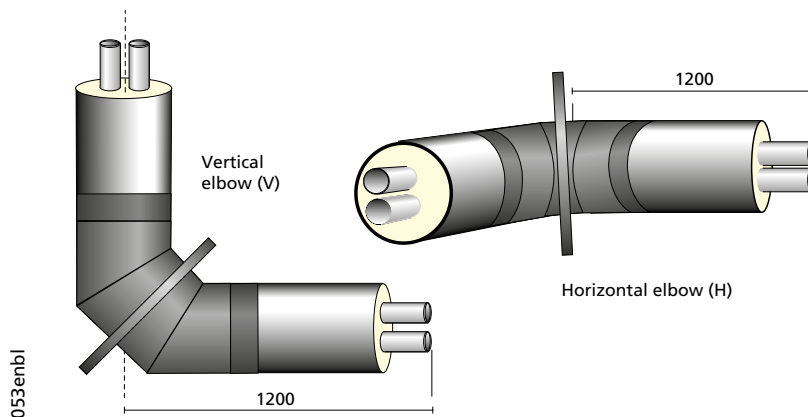

Code: Fintherm® Twins (insulation class) EA (DN/casing diameter) (H =horizontal or V =vertical)
Ex.: FTT 1 EA DN65+65/225 H

3.7 Shut-off valves

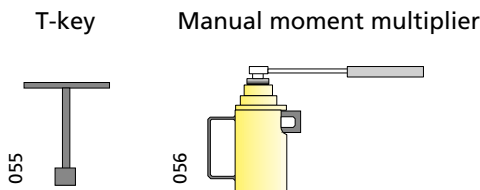
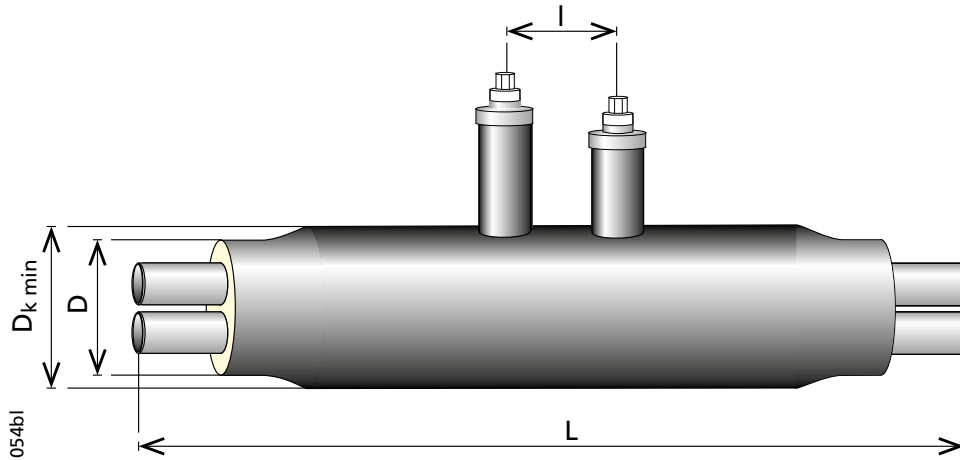

Based on the customer's request, valves are controlled either manually with a T-key (for dimensions of DN25 - 150), through a manual moment multiplier, or with a complete valve with gearbox (for dimensions of DN 200 - DN 250).

DN	L (mm)	l (mm)	D (mm)			D _{k min} (mm)		
			Insulation class 1	Insulation class 2	Insulation class 3	Insulation class 1	Insulation class 2	Insulation class 3
25 + 25	1700	300	140	160	180	160	180	200
32 + 32	1700	300	160	180	200	180	200	225
40 + 40	1700	300	160	180	200	180	200	225
50 + 50	1700	300	200	225	250	225	250	280
65 + 65	1700	400	225	250	280	250	280	315
80 + 80	1700	400	250	280	315	280	315	355
100 + 100	1700	400	315	355	400	355	400	450
125 + 125	2000	430	400	450	500	450	500	560
150 + 150	2000	470	450	500	560	500	560	630
200 + 200	2500	630	560	630		630	710	

Fintherm® Twins shut-off valves DN 20 - DN 250 are manufactured only as long spindle ball valves.

Valve Material:

- Valve body: carbon steel
- Ball and body: SIS 2333, AISI 304 (stainless steel)
- Gasket: PTFE, carbon reinforced
- Upper part of spindle: SIS 2333, AISI304 - stainless steel

Code: Fintherm® Twins (insulation class) S-V (DN/casing diameter)

Ex.: FTT 1 S-V DN80+80/250

A combined version of the shut-off valve with the air relief or drain valve can be supplied upon request.

3.8 Drain/Air relief valves

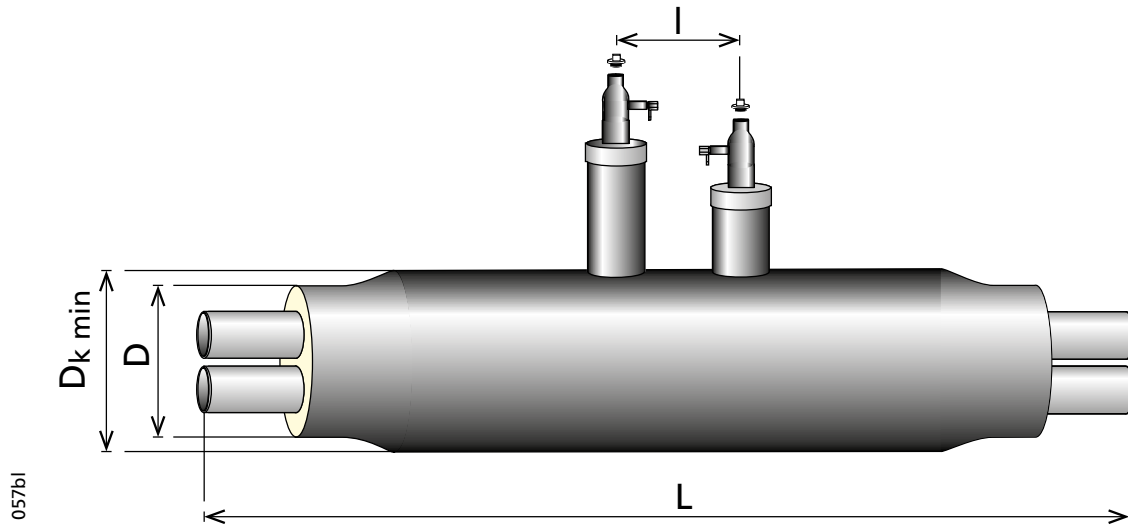

DN	L (mm)	l (mm)	D (mm)			D _{k min} (mm)		
			Insulation class 1	Insulation class 2	Insulation class 3	Insulation class 1	Insulation class 2	Insulation class 3
25 + 25	1700	300	140	160	180	160	180	200
32 + 32	1700	300	160	180	200	180	200	225
40 + 40	1700	300	160	180	200	180	200	225
50 + 50	1700	300	200	225	250	225	250	280
65 + 65	1700	400	225	250	280	250	280	315
80 + 80	1700	400	250	280	315	280	315	355
100 + 100	1700	400	315	355	400	355	400	450
125 + 125	2000	400	400	450	500	450	500	560
150 + 150	2000	400	450	500	560	500	560	630
200 + 200	2500	500	560	630		630	710	

The drain and air relief parts of the valves from DN 25 to DN 50 are produced with an increased wall thickness compared to the thickness of standard pipes, for dimension see Chapter 1.2.10.1.

Valve Material:

- Service pipe: carbon steel P235 GH
- Ball and body: SIS 2333, AISI 304 (stainless steel)
- Gasket: PTFE, carbon reinforced

Code: Fintherm® Twins (insulation class) D/A-V (DN pipe dimension/casing diameter) x (DN air/drain valve dimension)

Ex.: FTT 1 D/A-V DN80+80/250 x DN25

A combined version of the shut-off valve with the air relief or drain valve can be supplied upon request.

4 Fintherm® Special

4.1 Fintherm® Special PP-RCT

4.1.1 Technical specification

4.1.2 Pipes

4.1.3 Elbows

4.1.4 T-branches

4.1.5 Modular reducers

4.2 Fintherm Special PE

4.2.1 Technical Specifications

4.2.2 Pipes

4.2.3 Elbows

4.2.4 Branches

4 Fintherm® Special

In addition to the standard **FINTHERM** systems, we can offer other pre-insulated pipe systems in accordance to specific customer requirements. In terms of technology, these systems are similar and they only differ in using other/different material for the carrier pipe.

Conveyance pipes

The material for carrying pipes and pipes for the chemical industry is selected according to the specific application. The following suitable materials are available:

- Steel
- Stainless steel
- Acid-resistant steel
- Galvanised steel
- Copper
- Polyethylene (PE 100)
- Polypropylene (PPR)
- Polybutene (PB)
- Glass-fibre laminates
- PEX
- Cast iron

Casing

The casing protects the insulation against moisture and damage and effectively protects the pipes against corrosion. The casing of underground pipes must be watertight.

When selecting the casing, a suitable material for the specific installation must be taken into account, such as:

- Polyethylene: for underground installation or also for above-ground installation (provided that the cross-linked joints are used)
- Steel-zinc coated or aluminium spiral overlaid sheet (Spiro casing) for above-ground installation
- Steel-zinc coated or aluminium spiral overlaid sheet coated with PVC foil for above-ground installation
- Plastic-coated steel for demanding applications

Insulation

PUR foam is used as standard as in the previous types of pipelines for transporting liquids or gases at temperatures to 150°C. For higher temperatures, pipes containing polyurethane foam with enhanced temperature resistance of up to 160°C are available.

Fintherm® Special PP-RCT

4.1 Fintherm® Special PP-RCT

4.1.1 Technical specification

4.1.1.1 Polypropylene carrier pipe

The carrier pipes are made of polypropylene PP-RCT.

Density:	905 kg/m ³
Yield strength:	25 N/mm ²
Modulus of elasticity:	900 N/mm ²
Thermal conductivity:	0,24 W/mK
Thermal expansion coefficient:	1,5 · 10 ⁻⁴ K ⁻¹

Tested for drink water

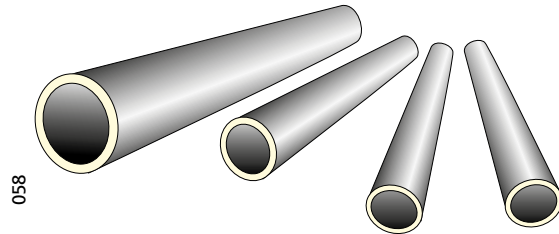

With a maximum working temperature of 70°C and maximum working overpressure of 1 MPa the pipe has a service life of 25 years. For higher operating parameters, please consult the FINTHERM® technical department.

4.1.1.2 Rigid PUR insulation

The rigid polyurethane foam (PUR) is produced by mixing polyalcohols (polyols) containing additives and isocyanates (MDI). The mixture is injected into pipes using a high-pressure foaming technique. The PUR foam used in the Fintherm® Special PP-RCT - HDPE system is CFC-free and meets the stringent requirements of European Standard EN 253.

Average cell size:	≤ 0,5 mm
Closed cell content:	≥ 88 %
Core density:	≥ 60 kg/m ³
Compressive strength:	≥ 0,3 MPa
Shear strength:	≥ 0,12 MPa
Thermal conductivity (+ 50°C):	0,026 W/mK

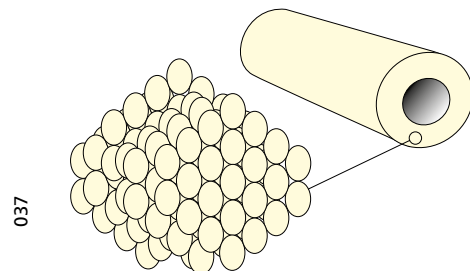

4.1.1.3 PE-HD casing pipe

Material PE-HD (Polyethylene, high density)

Density (+20°C):	~ 960 kg/m ³
Thermal conductivity:	0,43 W/mK
Thermal expansion coefficient:	1,8 · 10 ⁻⁴ K ⁻¹

See Chapter 1.1.3

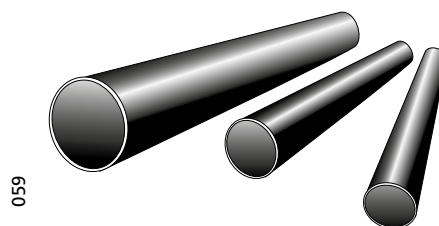

4.1.1.4 Spiro casing pipe

Spiro casing pipes are made of spiral overlaid mechanical deep-drawing steel zinc-coated sheets. Other material is available upon request.

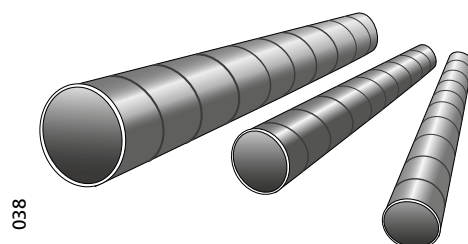

Fintherm® Special PP-RCT

4.1.2 Pipes

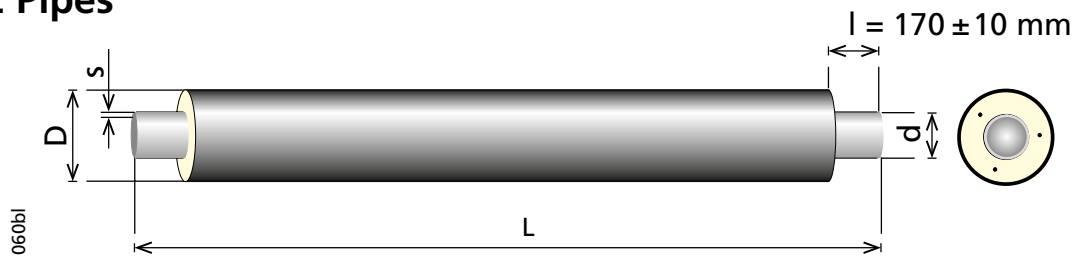

Insulation class 1

d (mm)	s (mm)	D (mm)	L (m)	Weight (kg/m)	Insulation thickness (mm)	Water volume (l/m)
32	4,4	90	6	1,6	26	0,4
40	5,5	110	6	2,2	32	0,7
50	6,9	110	6	2,4	27	1
63	8,6	125	6	3,1	28	1,6
75	10,3	140	6	3,9	30	2,3
90	12,3	160	6	5,1	32	3,4
110	15,1	200	6	7,6	42	5
125	17,1	225	6	9,6	47	6,5
160	14,6	250	6	10,8	41	13,4
200	18,2	315	6	16,6	53	21
250	22,7	400	6	26	70	32,9

Insulation class 2

d (mm)	s (mm)	D (mm)	L (m)	Weight (kg/m)	Insulation thickness (mm)	Water volume (l/m)
32	4,4	110	6	2,1	36	0,4
40	5,5	125	6	2,6	40	0,7
50	6,9	125	6	2,8	35	1
63	8,6	140	6	3,5	36	1,6
75	10,3	160	6	4,6	40	2,3
90	12,3	180	6	5,8	42	3,4
110	15,1	225	6	9,0	54	5
125	17,1	250	6	10,8	59	6,5
160	14,6	280	6	12,4	56	13,4
200	18,2	355	6	19,3	73	21
250	22,7	450	6	30,2	95	32,9

* If requested, please consult possibility of 12 m length pipes delivery, with FINTHERM® sales representatives.

Pipes are supplied in the PN20 pressure range. With the maximum working temperature of 70°C and maximum working overpressure of 1 MPa, the pipe has a service life of 25 years. For higher operating parameters, please consult the FINTHERM® technical department.

Pipes can be manufactured in different sizes and insulation thicknesses upon special request.

Code: FTS PP-RCT P (d carrier pipe outer diameter) / (casing pipe outer diameter) (length)

Ex.: FTS PP-RCT 1 P d63 / 125 6 m

Fintherm® Special PP-RCT

4.1.3 Elbows

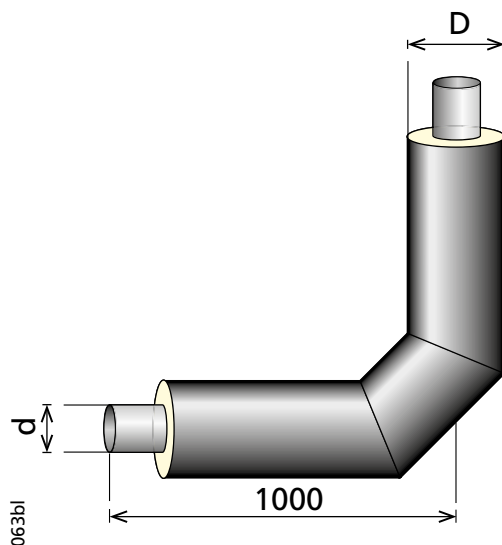

Prefabricated insulated elbows. For more details on dimensions, please contact us.

Fintherm® Special PP-RCT prefabricated insulated elbows are manufactured in the following angles: d32 - d63: 90°
d75 - d110: 90° (supplied with a butt weld; other angles upon special request.)

Prefabricated insulated elbows. For more details on dimensions, please contact us.

Code: FTS PP-RCT (insulation class) E (d dimension of FTS PP-RCT carrier pipe/casing diameter) (angle)
Ex.: FTS PP-RCT 1 E d40/110 90°

Fintherm® Special PP-RCT

4.1.4 T-branches

4.1.4.1 Straight T-branches

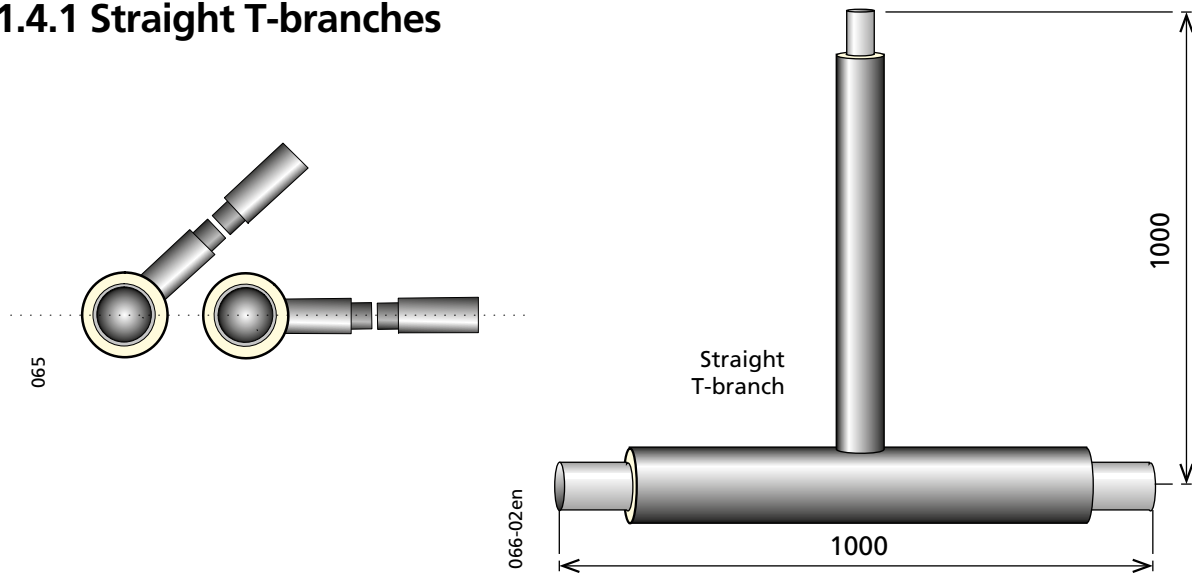

For more details on dimensions, please contact us.
Spiro casing can be supplied, as an option.

Code: FTS PP-RCT (insulation class) S-T (d dimension of FTS PP-RCT pipe/casing diameter)
x (d dimension of FTS PP-RCT branch dimension/casing diameter)
Ex.: FTS PP-RCT 1 S-T d110/180 x d75/140

4.1.4.2 Elevation T-branches

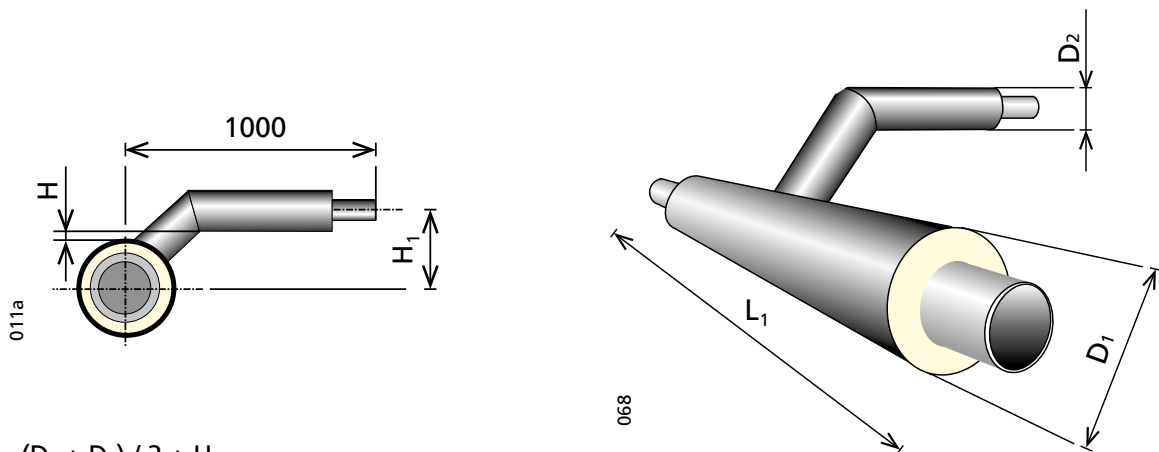

$$H_1 = (D_1 + D_2) / 2 + H$$

D_1, D_2 - diameter of the casing of the main pipe and the branch piece

$H=35$ mm distance between the surfaces of the casing pipes

For more details on dimensions, please contact us.
Spiro casing can be supplied, as an option.

Code: FTS PP-RCT (insulation class) E-T (d dimension of FTS PP-RCT carrier pipe/ casing diameter)
x (d diameter of FTS PP-RCT branch/ casing diameter)
Ex.: FTS PP-RCT 1 E-T d75/140 x d40/110

Fintherm® Special PP-RCT

4.1.4.3 Straight T-branch kit

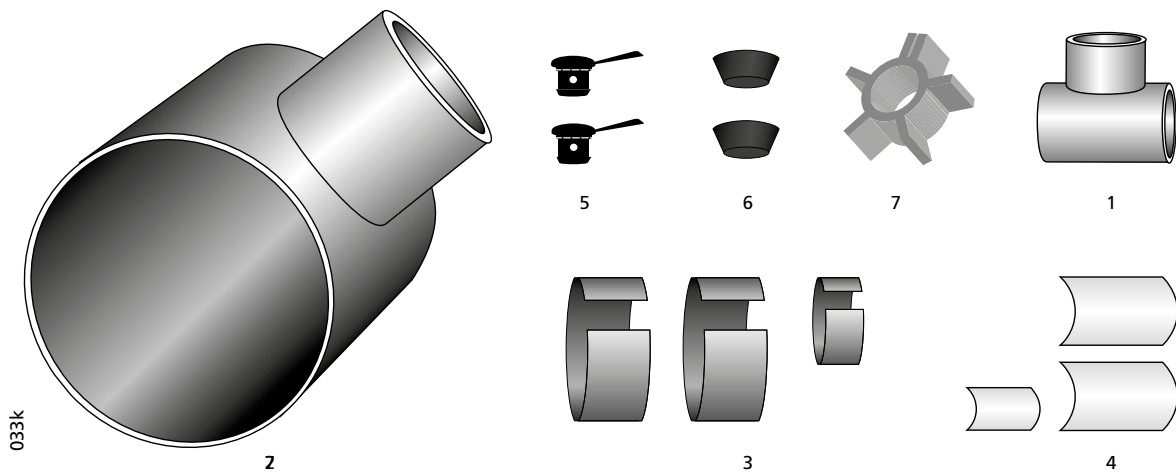

The kit comprises:

- | | |
|---|------------|
| 1. Branch | 1 piece |
| 2. Saddle | 1 piece |
| 3. Narrow shrink sleeves | 2+1 pieces |
| 4. Closing patches | 2+1 pieces |
| 5. Venting plugs | 2 pieces |
| 6. Welding plugs | 2 pieces |
| 7. Centring ring | 1 piece |
| - PUR components (quantity according to the dimensions) | |

For installation instruction, see Chapter 6.7.

Code: FTS PP-RCT T-kit ST (d dimension of FTS PP-RCT pipe/casing diameter)
/ (d dimension of FTS PP-RCT branch dimension/casing diameter)
Ex.: FTS PP-RCT 1 T-kit ST d75/140 x d32/90

Fintherm® Special PP-RCT

4.1.5 Modular reducers

The reduction kits (for installation in joints) are offered as standard shrinkable version. The advantage of the shrinkable modular reduction kit is that there are two independent systems for sealing a reduced joint.

The kit comprises:

- | | |
|---------------------------------|---|
| 1. PE shrinkable casing reducer | 1 piece |
| 2. PP-RCT reducer | 1 piece |
| 3. Narrow shrink sleeves | 2 pieces |
| 4. Closing patches | 2 pieces |
| 5. Venting plugs | 2 pieces |
| 6. Welding plugs | 2 pieces |
| 7. Electrical wire supports | 2 pieces |
| 8. Electrical wire connectors | 2 pieces |
| 9. Sealing tape | - PUR components
quantity according to the dimensions) |

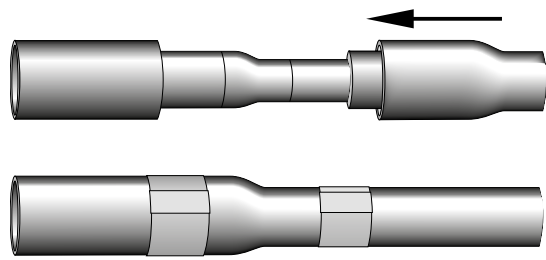
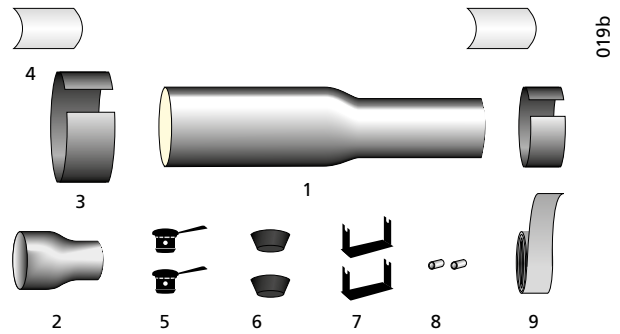

The PE casing reducer is placed over the smaller casing pipe prior to installation of PPR reducer.

The subsequent installation procedure of the shrinkable modular reduction kit is similar to the installation procedure for the DSJ double-sealed shrinkable joint.

Shrinkable version:

Code: FTS PP-RCT DSJ-SRK (PE larger casing diameter/smaller casing diameter)

PPR Reducer (larger d/smaller d)

Ex.: FTS PP-RCT DSJ-SRK PE160/140

PPR Reducer d110/d63

4.2 Fintherm® Special PE

4.2.1 Technical Specifications

4.2.1.1 Introductory Information

The Fintherm Special PE pre-insulated plastic piping system is used for ductless distribution systems for drinking water, geothermal water and other media. The PE 100 polyethylene media-carrying pipe is insulated with rigid polyurethane (PUR) foam with a polyethylene or galvanized spirally applied steel sheet casing. The Fintherm Special PE system has three "Nordic" system detection wires as standard features to detect possible leaks.

4.2.1.2 Parameters of the PE 100 Media-Carrying Pipe in Fintherm Special PE System

The media-carrying pipe is made of polyethylene PE 100. The allowable operating temperatures of the medium are defined by the temperature stability range of the polyethylene pipe, which is -50 °C to +50 °C. The maximum operating pressure depends on the chosen thickness of the media-carrying pipe. However, the specific properties of the media-carrying pipe depend on the particular supplier of the polyethylene piping. The type of the polyethylene media-carrying pipe is chosen by the customer according to the application, requirements and preferences, with the particular specifications of this material listed separately directly in the polyethylene pipe manufacturer's catalogue. Apart from standard polyethylene piping, for example polyethylene with an inner layer with enhanced chemical resistance or increased resistance to abrasive wear can be used for some purposes, or with a white layer for easier on-site installation (for better checking the internal cleanliness of the piping).

4.2.1.3 Parameters of PUR Foam in Fintherm Special PE System

Rigid polyurethane (PUR) foam is manufactured by mixing polyols containing additives with isocyanates (MDI); cyclopentane is used as a blowing agent in the process. The mixture is injected into tubes using the high-pressure foaming technique. PUR foam is CFC/HFC-free and meets the strict requirements of the European standard EN 253.

Average cell size:	≤ 0,5 mm
Closed cell content:	≥ 88 %
Core density:	≥ 60 kg/m ³
Compressive strength:	≥ 0,3 MPa
Shear strength:	≥ 0,12 MPa
Thermal conductivity (+ 50°C):	0,026 W/mK

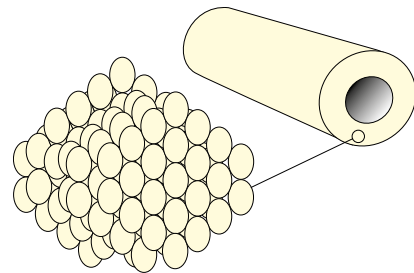

Fintherm® Special PE

4.2.1.4 Parameters of the PE HD Casing Pipe in Fintherm Special PE System

The specifications and thicknesses of the polyethylene casing pipe comply with EN 253.

Material PE-HD (high-density polyethylene)

Dimensions:	EN 253
Material:	PE-HD
Density (+20°C):	~ 960 kg/m ³
Heat conductivity:	0,43W/mK
Thermal expansion coefficient:	1,8 . 10 ⁻⁴ K ⁻¹
Melt flow index (MFI 190/5):	0,2 to 1,4
Carbon black content:	2,5 ± 0,5 % ASTM D-21603
Elongation at break:	≥ 350% ISO R-292
Impact strength:	≥ 10 mJ/mm ² ISO R-179
Tensile strength:	≥ 17 MPa ISO DIS 572B
The material is protected against the effects of UV radiation	

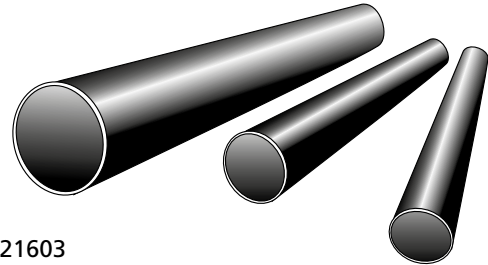

Fintherm® Special PE

4.2.2 Fintherm Special PE Pipes

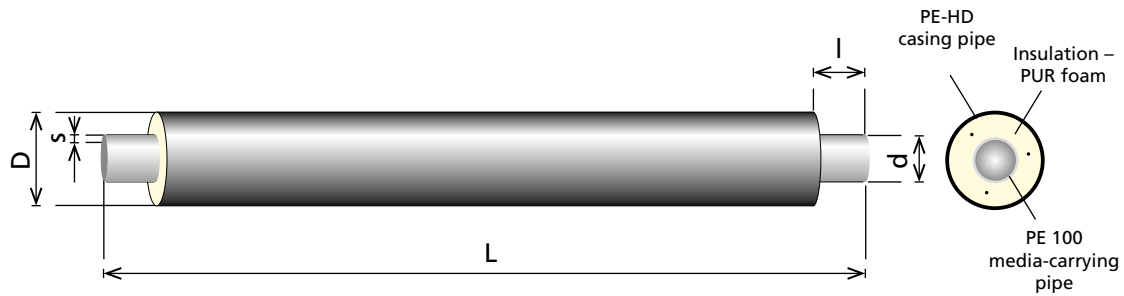

1. Insulation class

d . s SDR 17 (PN10)	D (mm)	L (m)	l (mm)	d . s SDR 11 (PN16)	D (mm)	L (m)	l (mm)
32x1,9	90	6,12	170	32x3,0	90	12	170
40x2,4	110	6,12	170	40x3,7	110	12	170
50x3,0	110	6,12	170	50x4,6	110	12	170
63x3,8	125	6,12	170	63x5,8	125	12	170
75x4,5	140	6,12	170	75x6,8	140	12	170
90x5,4	160	6,12	170	90x8,2	160	12	170
110x6,6	200	6,12	170	110x10,0	200	12	170
125x7,4	225	6,12	170	125x11,4	225	12	170
140x8,3	225	6,12	170	140x12,7	225	12	170
160x9,5	250	6,12	170	160x14,6	250	12	170
180x10,7	280	6,12	170	180x16,4	280	12	170
200x11,9	315	6,12	170	200x18,2	315	12	170
225x13,4	315	6,12	170	225x20,5	315	12	170
250x14,8	400	6,12	170	250x22,7	400	12	170
280x16,6	400	6,12	170	280x25,4	400	12	170
315x18,7	450	6,12	170	315x28,6	450	12	170
355x21,1	500	6,12	170	355x32,2	500	12	170
400x23,7	560	6,12	170	400x36,3	560	12	170

On special request, the pipes are manufactured in other lengths, dimensions and insulation thicknesses.

The pipes are supplied in a minimum pressure rating of PN10. At a maximum temperature of 20 °C and a maximum operating pressure of 1.0 MPa, the service life of the piping is 50 years. Higher operating parameters must be consulted in advance with Fintherm® representatives.

Name: FTS PE P (diameter d of FTS PE carrying pipe/casing pipe diameter) (length) SDR
 For example: FTS PE 1 P d 63/125 12 m SDR17

Fintherm® Special PE

2. Insulation class

d . s SDR 17 (PN10)	D (mm)	L (m)	l (mm)	d . s SDR 11 (PN16)	D (mm)	L (m)	l (mm)
32x1,9	110	6,12	170	32x3,0	110	12	170
40x2,4	125	6,12	170	40x3,7	125	12	170
50x3,0	125	6,12	170	50x4,6	125	12	170
63x3,8	140	6,12	170	63x5,8	140	12	170
75x4,5	160	6,12	170	75x6,8	160	12	170
90x5,4	180	6,12	170	90x8,2	180	12	170
110x6,6	225	6,12	170	110x10,0	225	12	170
125x7,4	250	6,12	170	125x11,4	250	12	170
140x8,3	250	6,12	170	140x12,7	250	12	170
160x9,5	280	6,12	170	160x14,6	280	12	170
180x10,7	315	6,12	170	180x16,4	315	12	170
200x11,9	355	6,12	170	200x18,2	355	12	170
225x13,4	355	6,12	170	225x20,5	355	12	170
250x14,8	450	6,12	170	250x22,7	450	12	170
280x16,6	450	6,12	170	280x25,4	450	12	170
315x18,7	500	6,12	170	315x28,6	500	12	170
355x21,1	560	6,12	170	355x32,2	560	12	170
400x23,7	630	6,12	170	400x36,3	630	12	170

On special request, the pipes are manufactured in other lengths, dimensions and insulation thicknesses.

Name: FTS PE P (diameter d of FTS PE carrying pipe/casing pipe diameter) (length) SDR
 For example: FTS PE 2 P d 63/140 12 m SDR17

4.2.3 Fintherm Special PE Elbows

Fintherm Special PE prefabricated insulated elbows are manufactured in standard 45° and 90° angles. Other angles and arm lengths are available on special request.

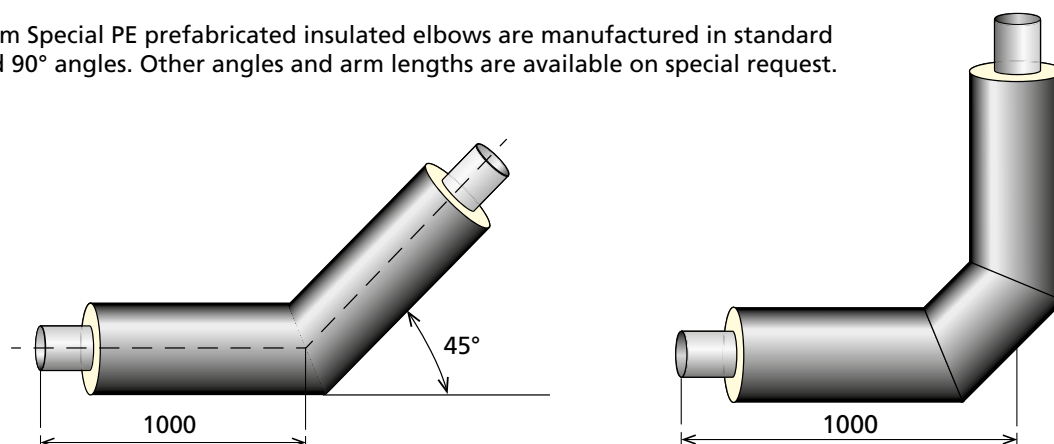

Name: FTS PE (insulation class) E (diameter d of FTS PE carrying pipe/casing pipe diameter) (angle) SDR
 For example: FTS PE 1 E d 63/125 90° SDR17

4.2.4 Fintherm Special PE Branches

Other fittings are made to order according to the manufacturer's capabilities and specific customer requirements for individual projects. For more detailed information, please get in touch with a sales representative of Fintherm a.s.

Straight branches

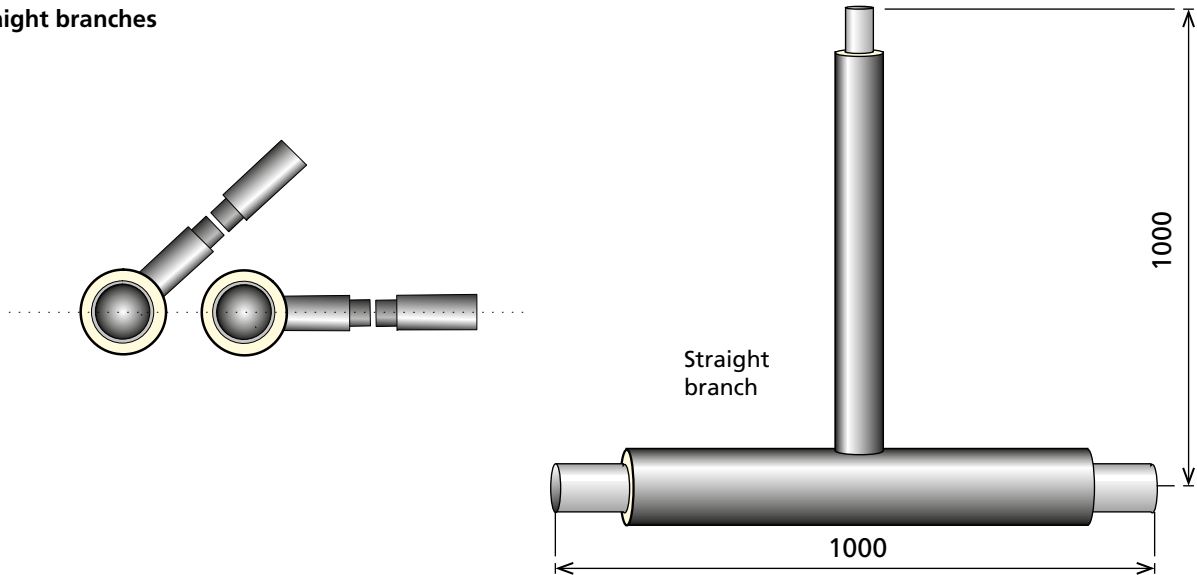

Name: FTS PE (insulation class) S-T (diameter d of FTS PE carrying pipe/casing pipe diameter) x (diameter d of FTS PE branch/casing diameter) SDR
 For example: FTS PE 1 S-T d 63/125 x d 40/110 SDR17

Elevated branches

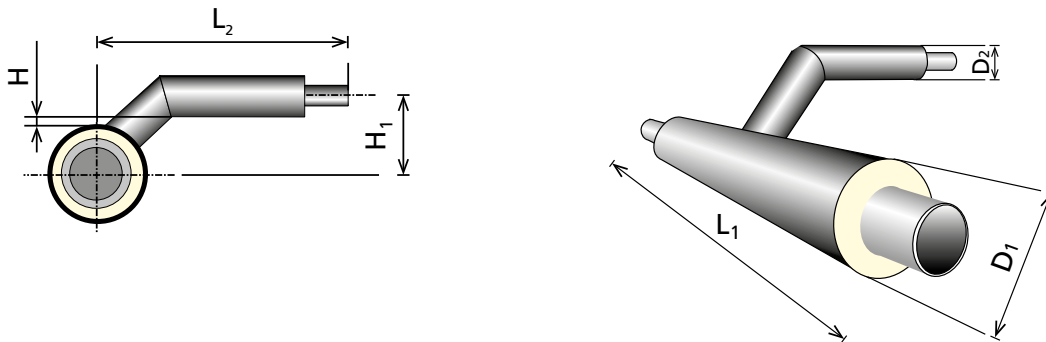

$$H_1 = (D_1 + D_2) / 2 + H$$

D_1, D_2 - casing diameter of the main and branching lines
 $H=35$ mm – distance between casing pipe surfaces

More detailed information and dimensions on request.
 If required, a spiral casing version can also be supplied.

Name: FTS PE (insulation class) E-T (diameter d of FTS PE carrying pipe/casing pipe diameter) x (diameter d of FTS PE branch/casing diameter) SDR
 For example: FTS PE 1 S-T d 63/125 x d 40/110 SDR17

5 Accessories

- 5.1 Expansion polyethylene profile pads**
- 5.2 Channel rubbers**
- 5.3 Marking tapes**
- 5.4 Hard EPS foam beams**
- 5.5 Joints**
- 5.6 End sealing of insulation**
- 5.7 End fitting kit**
- 5.8 Connection pipe**
- 5.9 Tapping valve**
- 5.10 Polyethylene valve wells**
- 5.11 Valve spindle extender**
- 5.12 Leakage detection system**

Accessories

5.1 Expansion polyethylene profile pads

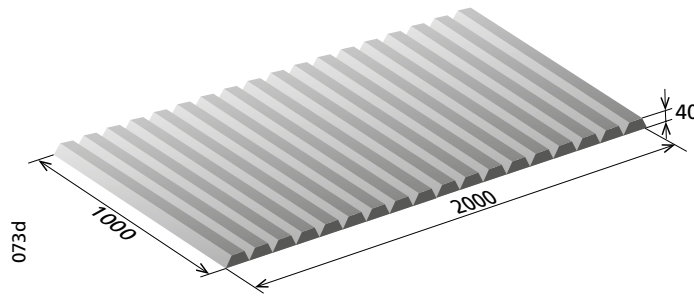

Expansion polyethylene profile pads allow the thermal expansion of pre-insulated pipes installed in the ground. They have to be used at bends, branches, reducers, valves, and end fittings. Material of expansion polyethylene profile pads is cross-linked Polyethylene, which has a long service life because it has increased resistance to the effects of soil moisture and chemicals.

The profile pads (2x1 m) are cut on-site to the required size according to the outer diameter of the pipes to be sheathed.

Multi layers of expansion pads can be used if it is necessary to handle larger expansion and according to the type of soil, and at the same time it is necessary to sheathe the pipes so as to avoid the accumulation of heat on the pipe casing.

In the case of pre-heating, the pre-insulated pipes are covered on both sides.

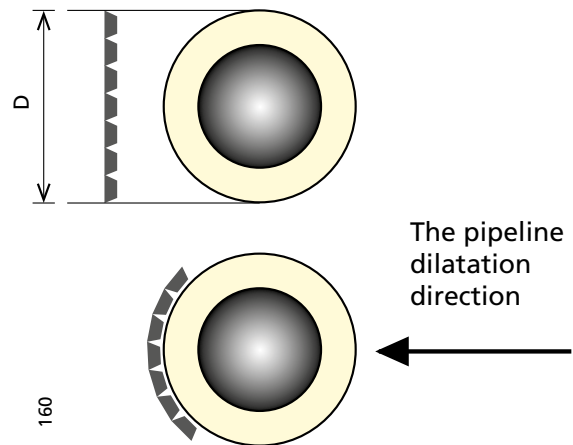

Density: $30 \pm 4 \text{ kg/m}^3$

Water absorption: vol.% $\leq 1,9$

Compressibility 10% at compression of 16 kPa = 4 mm
 Compressibility 25 % at compression of 35 kPa= 10 mm
 Compressibility 50 % at compression of 80 kPa= 20 mm

Code: Fintherm® Standard FPP (length) x (height) x (width)
 Ex.: FTS FPP 2000x1000x40

For up to DN 250, we provide pre-cut profiled board segments in the following sizes:

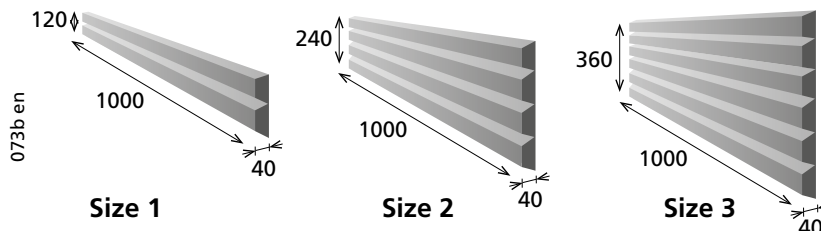

Casing diameter (mm)	Size of cut segments
90 - 140	1
160 - 225	2
250 - 315	3

Code: Fintherm® Standard FPP (length) x (height) x (width)
 Ex.:

Size 1: FTS FPP 1000x120x40
 Size 2: FTS FPP 1000x240x40
 Size 3: FTS FPP 1000x360x40

Accessories

5.2 Channel rubbers

5.2.1 Channel rubbers

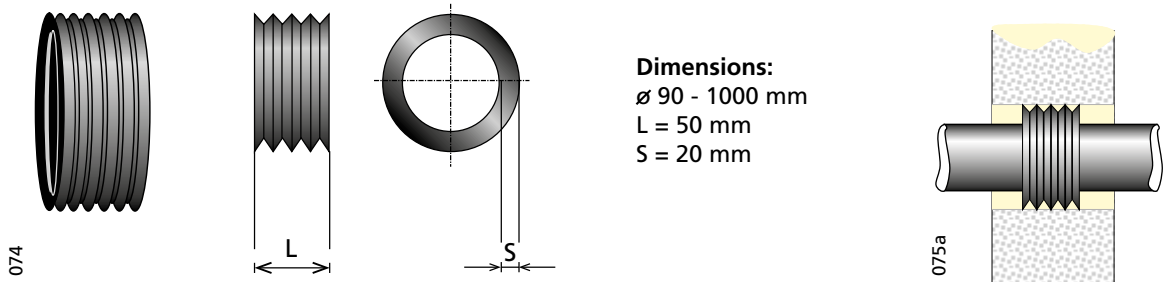

The channel rubber is placed around the casing pipe prior to welding and casting the wall entry. The channel rubber is usually situated in the wall entry and functions as a watertight seal. If the wall thickness is greater than 300 mm, we recommend installing two channel rubbers.

Code: Fintherm® Standard CR (outer casing diameter)
Ex.: FTS CR 180

5.2.2 VDW seal

The seal of VDW type is designed to transfer large radial and axial piping movements of up to +/- 40 mm. It is used for sleeves with diameters from 75 to 800 mm and a maximum permanent operating temperature of up to 120°C. It was tested and certified by the MFPA Leipzig testing body, up to the water pressure of 0.5 bar. The seal is made of EPDM elastomer.

Outer pipe diameter D (mm)	Max. opening/ duct diameter D _o (mm)	Outer diameter of flange D _p (mm)
75-90-110	150/200	350
125-140-160	200/250	400
180-200-225	300	450
250-280-315	350/400	565
355-400	450/500	650
450-500	550/600	750
560-630	650/700	880
670	800	1050
710-800	800/900	1050

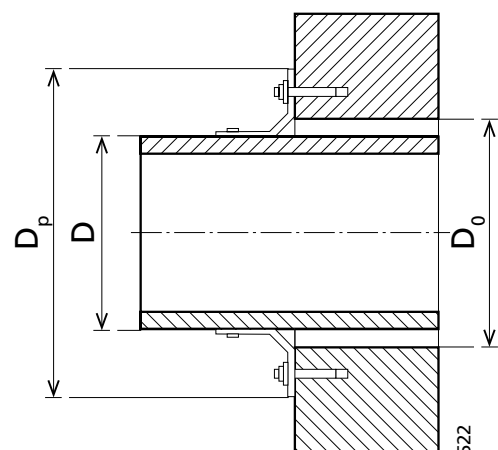
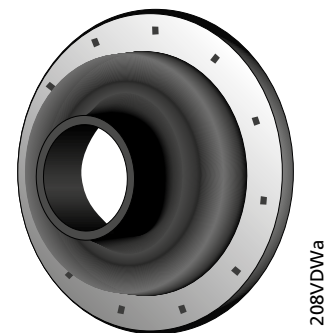

Name: Fintherm® Standard VDW (outer pipe diameter)
E.g.: FTS VDW 75-90-110

Accessories

5.2.3 Link seal

The Link Seal bushing prevents moisture, pressurized water (up to 5 bar) and gases from entering the building. It is therefore suitable for complicated conditions where the required characteristics include hydrostatic tightness (e.g. high groundwater level) or gas tightness (gases in the soil) of the passage. However, this bushing only allows for minimal axial and radial dilatations, which must be taken into account when the new route is designed. By default, version "BS" is supplied, made of EPDM rubber and stainless steel screws.

The specific type of bushing (number of segments) is determined by a Fintherm® representative, based on the available data concerning the outer diameter of the pipe and the inner diameter of the opening/duct.

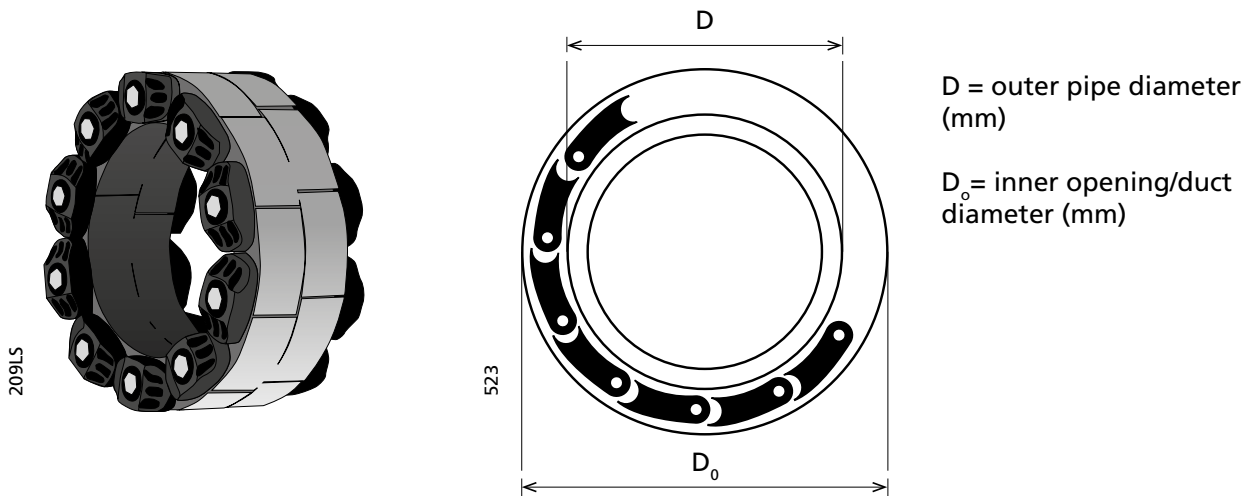

D = outer pipe diameter (mm)

D_0 = inner opening/duct diameter (mm)

Name: Fintherm® Standard LS (outer pipe diameter D / inner opening diameter D_0)

E.g.: FTS LS 200/250

5.3 Marking tape

Marking tape is supplied in rolls.

Green as standard, but other colours may be available upon request

Code: Fintherm® Standard MT (Length in m)

Ex.: FTS MT 216 m

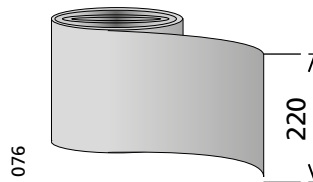

Accessories

5.4 Hard EPS foam beams (cradles)

Beams of hard EPS foam are used as auxiliary cradles for pre-insulated pipes with a casing pipe diameter of up to 315 mm. Unlike wooden beams, they do not need to be removed from the trench before backfilling. They are more convenient to use, given the speed of installation. The beams are placed under the pipe and are spaced at 2.0 m apart. The beam dimensions are 100 x 100 x 1000 mm.

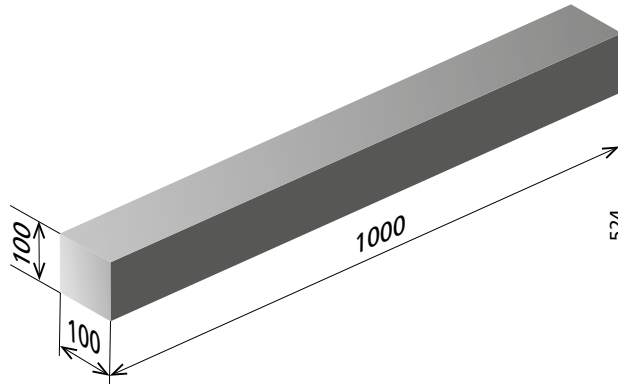

Accessories

5.5 Joints

Joints are used for the insulation of a pipeline in the welded areas of the carrier pipes, connecting its individual segments. The joints have dual functionality: they protect the PUR insulation against mechanical damage and prevent moisture from entering. Selecting the right type of joints significantly influences the quality and service life of the pipe system.

Provided that the installation procedures are followed carefully, all joints offered are suitable for sandy, clay, dry, and wet soil and meet the requirements of EN 489.

All materials required for joint installation, including components for the production of polyurethane foam, which comes in bottles, cans, or in the form of prefabricated parts, are provided as standard. To achieve the highest quality of joints for larger dimensions and the correct mechanical and thermal insulating properties, FINTHERM® offer mechanical foaming of these joints directly on-site.

Types of joints according to their technical performance and application:

DSJ double-sealed shrinkable joints

are suitable for most applications and this is the most commonly used joint type. Two independent seal systems prevent moisture from entering the PUR insulation.



Spiro Spoj

The joints are made of spiral overlaid steel zinc-coated sheets, being UV resistant and designed primarily for above-ground spiro-casing piping systems.



JT electrically weldable shrinkable joints

are suitable for the most demanding conditions with the least favourable load, or for sites with ground water.



Extrusion longitudinally weldable electric joint MITTEL

High-quality and durable electrically weldable joint Mittel is suitable not only for implementation of new pipelines, but also for the most demanding repairs.



JZ cross-linked shrinkable joints

are designed for most demanding conditions subjected to adverse stress and can also be used in sites where ground water occurs.



See below for more information on joints.

Accessories

The selection of a specific joint type depends primarily on:

- Joint size
- Soil factors (level of ground and surface water, oil and other contamination)
- Knowledge and experience of the assembly personnel
- Number of thermal cycles
- Stress rate the joint is exposed to
- Service life of the joint
- Requirements of the designer and the project investor

Thanks to our many years of experience, our sales representatives or engineers will recommend the best type of joint for the project.

The joint installation must be done in accordance with EN 13941 standards by trained personnel with valid certification from FINTHERM®.

The certification confirms the theoretical and practical knowledge of installation of pre-insulated pipe joints. This knowledge and practical testing during the training programme helps minimize risks and possible damage which may be incurred by failure to adhere to the correct procedures and to adapt the installation of the joints to the environment.

After the training programme, the installation workers will have gained the following knowledge:

- Information about the types of joints used and installation procedures
- Joint foaming process using cast PUR foam
- Safety regulations applicable to the installation of the joints and PUR foam
- Storage conditions for the individual components
- Disposal of waste generated during the installation of joints
- Leak detection systems used for pre-insulated pipes (Nordic, Brandes, Hagenuk, and Isotronic)

Information on the procedures of joint installation is provided in the installation manual, which is available at www.fintherm.cz

Accessories

5.5.1 Double sealed shrinkable joint

The PE casing shrinks to the outside of the casing pipe after being torch heated. The sealing tape is considered to be the main sealing element and it is already integrated in the PE casing. Shrinkable sealing sleeves covering the edges of the casing are used as additional sealing in accordance with the requirements of standard EN 489 for double-sealed joints.

DSJ double-sealed shrinkable joint includes:

- | | | | |
|--------------------------|----------|--|----------|
| 1. PE-shrinkable casing | 1 piece | 6. Detection wire supports | 2 pieces |
| 2. Narrow shrink sleeves | 2 pieces | 7. Detection wire connectors | 2 pieces |
| 3. Patches | 2 pieces | PE casings are supplied with the sealing tape pasted on. | |
| 4. Venting plugs | 2 pieces | PUR components | |
| 5. Welding plugs | 2 pieces | (quantity according to the dimensions) | |

The shrinkable cover casing comes in a protective white foil of polyethylene that protects it from dirt, moisture, and sunlight. The protective foil is removed just before heating the joint.

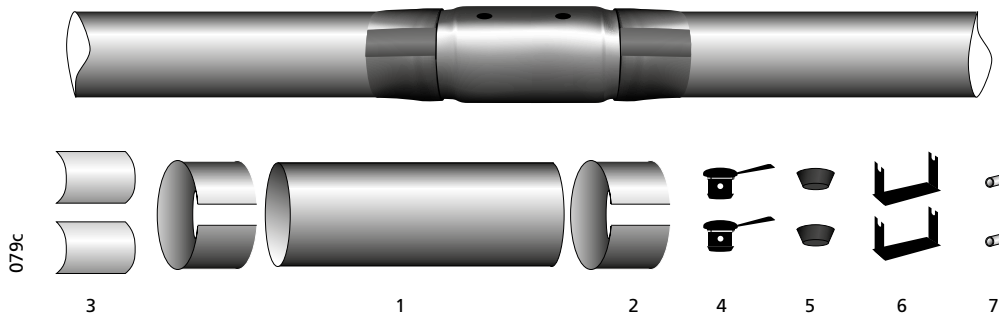

DSJ joints are offered in the following standard lengths according to the diameter of the casing pipe:

Casing pipe diameter	Length of the connection
ø 90 - 560 mm	600 mm
ø 630 - 1000 mm	700 mm

See Chapter 6.5 for the dose rate of PUR components. See the installation manual for workflow.

Code: Fintherm® Standard DSJ (DN dimension/casing diameter)

Ex.: FTS DSJ DN100/200

5.5.1.1 Double sealed shrinkable joint for compensator

Double-sealed joints with a longer casing and with a bigger quantity of PUR foam are intended to insulate one time compensators.

Casing pipe diameter	Length of the connection
ø 90 - 125 mm	880 mm
ø 140 - 180 mm	950 mm
ø 200 - 280 mm	1080 mm
ø 315 - 400 mm	1120 mm
ø 450 - 710 mm	1260 mm

Code: Fintherm® Standard OB-DSJ (DN dimension/casing diameter)

Ex.: FTS OB-DSJ DN100/200

Accessories

5.5.2 Spiro joint

The kit contains:

- | | |
|--|-----------|
| 1. Coiled casing metal plate | 1 piece |
| 2. Sealing tape | 1 piece |
| 3. Rivets | 20 pieces |
| 4. Covering metal patch | 1 piece |
| - PUR components | |
| (quantity according to the dimensions) | |

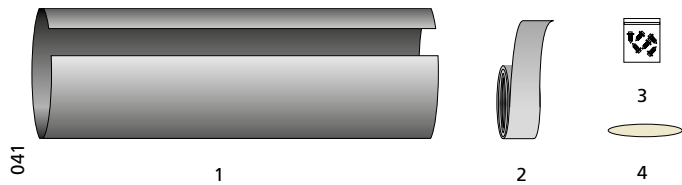

Standard length of Spiro joints is 500 mm.
The covering metal patch is installed by four rivets.

Code: Fintherm® Standard Spiro connection pipe (DN pipe dimension / casing diameter)
Ex.: FTSS joint DN200/315

5.5.3 Electrically weldable joint

The standard electrically weldable joint combines the advantages of a shrinking sleeve which shrinks if flame-heated to a diameter of a guard tube and the final electrical welding of plastics by integrated welding bands with electrical conductors. Welding is performed by a special welding machine controlled by the microcomputer which adjusts the welding process to the ambient conditions. This results in a solid, high-quality joint along the entire circumference.

Electrically weldable shrinkable joints includes:

- | | | | |
|------------------------------|----------|--|----------|
| 1. Electro shrinkable casing | 1 piece | 5. Detection wire supports | 2 pieces |
| 2. Welding resistance wires | 2 pieces | 6. Detection wire connectors | 2 pieces |
| 3. Venting plugs | 2 pieces | PUR components | |
| 4. Welding plugs | 2 pieces | (quantity according to the dimensions) | |

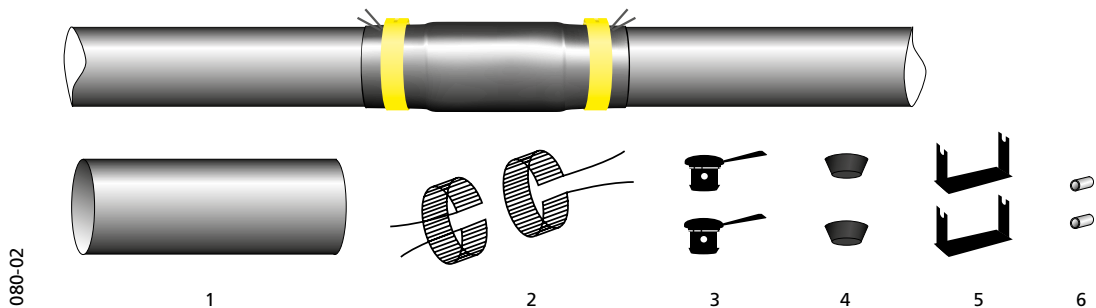

Joints are offered as standard in length of 700 mm.

See Chapter 6.5. for the dose rate of PUR components.

Code: Fintherm® Standard JT (DN dimension / casing diameter)
Ex.: FTS JT DN100/200

Accessories

5.5.3.1 Electrically weldable joint for compensator

Electrically weldable joints with a longer casing and with a bigger quantity of PUR foam are intended to insulate one time compensators.

Casing pipe diameter	Length of the connection
ø 90 - 125 mm	880 mm
ø 140 - 180 mm	950 mm
ø 200 - 280 mm	1080 mm
ø 315 - 400 mm	1120 mm
ø 450 - 710 mm	1260 mm

Code: Fintherm® Standard OB-JT (DN dimension/casing diameter)
Ex.: FTS OB-JT DN100/200

5.5.4 Extrusion longitudinally weldable electric joint MITTEL

High-quality and durable electrically weldable joint Mittel is suitable not only for implementation of new pipelines, but also for the most demanding repairs. Thanks to its unique technology, using the longitudinal extrusion weld, it can also be used for the existing (closed) lines. The joint sleeve comprises welding bands with electrical conductors for the final welding of plastics. It is longitudinally split to facilitate its placement and positioning in the pipeline, not shrinkable in heat. Once the sleeve is fitted to the desired location, its final welding is performed using the microcomputer-controlled welding machine, where the welding process is automatically adapted to the ambient conditions. Subsequently, the sleeve is longitudinally welded by the extrusion welding machine, to achieve a solid, high-quality joint.

The WE Extrusion welded longitudinal joint includes:

- | | | | |
|-----------------------------|----------|------------------------------|--|
| 1. PE-non shrinkable casing | 1 piece | 5. Detection wire supports | 2 pieces |
| 2. Welding metal band | 2 pieces | 6. Detection wire connectors | 2 pieces |
| 3. Venting plugs | 2 pieces | PUR components | (quantity according to the dimensions) |
| 4. Welding plugs | 2 pieces | | |

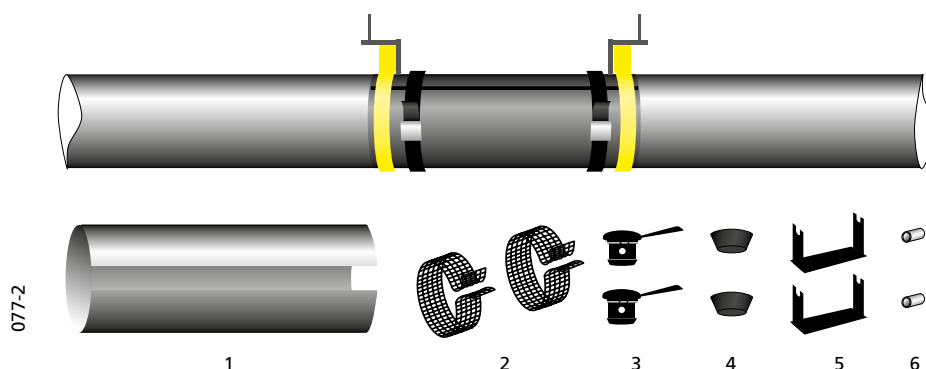

Casing length L = 600mm for D = 90-560mm
Casing length L = 700mm for D = 630-710mm
See Chapter 6.5 for the dose rate of PUR components.

Code: Fintherm® Standard JM (DN dimension/casing diameter)
E.g.: FTS JM DN100/200

Accessories

5.5.5 Cross-linked shrinkable joint

The cross-linked casing shrinks to the outside of the casing pipe after being torch heated. The crosslinked shrinkable casing has an integrated seal on each side. The casing's material has a high shrinkage rate, which gives the joint a high adherence pressure for the service life of the pipe. It is therefore not necessary to use shrinkable protective sleeves as is the case for the DSJ joint.

JZ cross-linked shrinkable joints includes:

- | | | | |
|-----------------------------------|----------|------------------------------|--|
| 1. Cross-linked shrinkable casing | 1 piece | 4. Detection wire connectors | 2 pieces |
| 2. Venting plugs | 2 pieces | 5. Detection wire supports | 2 pieces |
| 3. Welding plugs | 2 pieces | PUR components | (quantity according to the dimensions) |

The cross-linked heat shrinkable sleeve comes in a protective white foil of polyethylene that protects it from dirt and moisture. The protective foil is removed just before heating the joint.

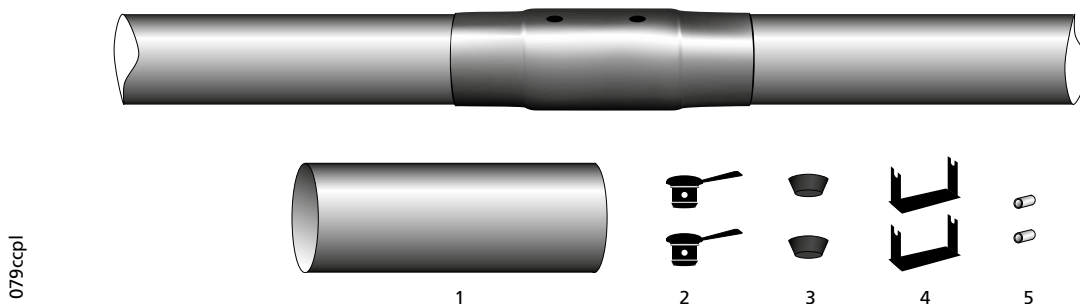

JZ joints are offered in the following standard lengths depending on the diameter of the casing pipe and customer requirements:

Casing pipe diameter	Length of the connection
ø 90 - 990 mm	600-700 mm
ø 280 - 990 mm	600-750 mm

See Chapter 6.5. for the dose rate of PUR components.

Code: Fintherm® Standard JZ (DN dimension/casing diameter)

Ex.: FTS JZ DN100/200

5.5.6 Twins joint

For the **Fintherm®** Twins system, we offer all joint types mentioned in Chapters 6.4.1 to 6.4.4. The only difference is the foam dosage.

Change in the way of coding joints

Code: Fintherm® Twins (joint type) (DN+DN / casing diameter)

Ex.: FTT DSJ DN40+40/160

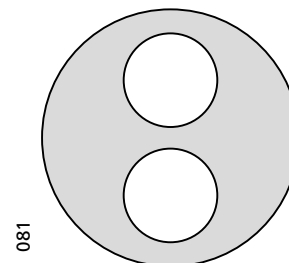

5.5.7 Accessories for joints

Upon the customer's request, we supply individual replacement joint components separately. It is also possible to separately order upper patches for the additional covering of welding plugs.

Accessories

5.5.8 Dosage of PUR foam

5.5.8.1 Dosage of PUR foam from bottles

Calculated values:

Density 85 kg/m³ of polyurethane

DSJ joint type

Length of the foamed part: 350 mm

Components:

MDI: Diphenylmethane diisocyanate - dark, viscous, higher quantity

Polyol: Polyether alcohol - light, bright, viscous

Dosage of foam for Fintherm® Standard

DN	Insulation class 1		Insulation class 2		Insulation class 3	
	Casing diameter [mm]	Bottle size	Casing diameter [mm]	Bottle size	Casing diameter [mm]	Bottle size
25	90	1	110	2	125	3
32	110	2	125	3	140	4
40	110	2	125	3	140	4
50	125	3	140	4	160	6
65	140	3	160	5	180	6
80	160	4	180	6	200	6,1
100	200	6,1	225	8	250	9
125	225	7	250	8	280	9
150	250	8	280	9	315	10
200	315	9	355	7+8	400	9,1+7/ 9+9
250*	400	7+8	450	9,1+9,1	500	10+11
300	450	8+8	500	10+11	560	11+11
350	500	9+9,1	560	9+9+9		
400**	560	9+9,1+6				

Dosage of foam for Fintherm® Twins

DN	Insulation class 1		Insulation class 2	
	Casing diameter [mm]	Bottle size	Casing diameter [mm]	Bottle size
25	140	4	160	5
32	160	5	180	6
40	160	5	180	6
50	200	6.1	225	8
65	225	7	250	8
80	250	8	280	9
100	315	10	355	11

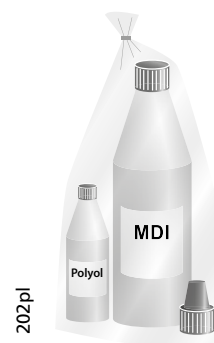

* For the foaming of joints in larger dimensions, we offer the mechanical foaming of these joints directly on-site, to achieve the highest quality of joints and the correct mechanical and thermal insulating properties; alternatively we can supply the foam components in canisters.

** From DN 400, use the bottles in extreme cases only.

5.5.8.2 Prefabricated PUR insulation foam

To request prefabricated insulating foam modules, as an alternative to foam in bottles or canisters, please put a "PU" abbreviation in your order after the joint specification. Prefabricated insulation is used especially with the temperature parameters for the joint assembly out of range (heat/cold).

The supply also includes a foil for securing the insulation position at the joint.

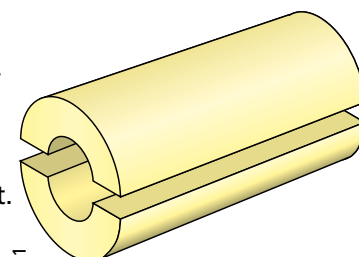

Code: Fintherm® Standard DSJ (DN of piping/diameter of casing)-PU

Ex.: FTS DSJ DN100/250-PU

Accessories

5.5.8.3 Dosage of PUR foam from canisters

Calculated values:

Density 85 kg/m³ of polyurethane

DSJ joint type

Length of the foamed part: ≤ DN350 = 350 mm
 ≥ DN400 = 390 mm

Components:

MDI: Diphenylmethane diisocyanate - dark, viscous, higher quantity

Polyol: Polyether alcohol - light, bright, viscous

Dosage of foam for Fintherm® Standard									
DN	Insulation class 1			Insulation class 2			Insulation class 3		
	Casing diameter [mm]	Polyol [liter]	Isocyanate [liter]	Casing diameter [mm]	Polyol [liter]	Isocyanate [liter]	Casing diameter [mm]	Polyol [liter]	Isocyanate [liter]
25	90	0,107	0,150	110	0,154	0,216	125	0,195	0,272
32	110	0,148	0,207	125	0,188	0,263	140	0,233	0,326
40	110	0,143	0,200	125	0,183	0,256	140	0,228	0,319
50	125	0,170	0,238	140	0,215	0,301	160	0,289	0,404
65	140	0,194	0,271	160	0,268	0,374	180	0,347	0,485
80	160	0,247	0,346	180	0,326	0,456	200	0,410	0,573
100	200	0,360	0,503	225	0,485	0,678	250	0,619	0,865
125	225	0,421	0,589	250	0,555	0,776	280	0,726	1,015
150	250	0,469	0,656	280	0,640	0,895	315	0,875	1,224
200	315	0,682	0,954	355	0,990	1,384	400	1,350	1,887
250	400	1,090	1,524	450	1,508	2,109	500	2,001	2,798
300	450	1,211	1,693	500	1,704	2,382	560	2,383	3,332
350	500	1,493	2,087	560	2,172	3,037	630	3,159	4,418
400	560	2,003	2,801	630	3,107	4,345	710	4,302	6,015
450	630	2,629	3,676	710	3,824	5,346	800	5,532	7,735
500	710	3,285	4,593	800	4,993	6,982	900	6,850	9,578
600	800	3,744	5,236	900	5,601	7,832	1000	7,999	11,184
700	900	4,140	5,789	1000	6,537	9,141	1100	8,947	12,510
800 to 1200 upon request									

Dosage of foam for Fintherm® Twins									
DN	Insulation class 1			Insulation class 2			Insulation class 3		
	Casing diameter [mm]	Polyol [liter]	Isocyanate [liter]	Casing diameter [mm]	Polyol [liter]	Isocyanate [liter]	Casing diameter [mm]	Polyol [liter]	Isocyanate [liter]
25	140	0,229	0,320	160	0,302	0,423	180	0,382	0,533
32	160	0,289	0,405	180	0,369	0,515	200	0,452	0,632
40	160	0,279	0,390	180	0,358	0,501	200	0,442	0,617
50	200	0,416	0,582	225	0,541	0,757	250	0,675	0,944
65	225	0,499	0,698	250	0,633	0,885	280	0,804	1,124
80	250	0,592	0,827	280	0,763	1,066	315	0,998	1,395
100	315	0,898	1,255	355	1,205	1,685	400	1,565	2,188
125	400	1,438	2,010	450	1,856	2,596	500	2,349	3,285
150	450	1,684	2,354	500	2,177	3,043	560	2,856	3,993
200	560	2,470	3,454	630	3,458	4,835	710	4,527	6,330
250	710	4,007	5,603	800	5,536	7,740	900	7,197	10,064

For foam dosage for different lengths of joints, the quantity of foam components is multiplied by a factor x:

$$X = \frac{\text{new length of the foamed part of the joint (mm)}}{\text{standard length of the foamed part of the joint (mm)}}$$

For dosing ratios of larger dimensions, please contact the FINTHERM® technical department.

Accessories

5.6 End sealing of insulation

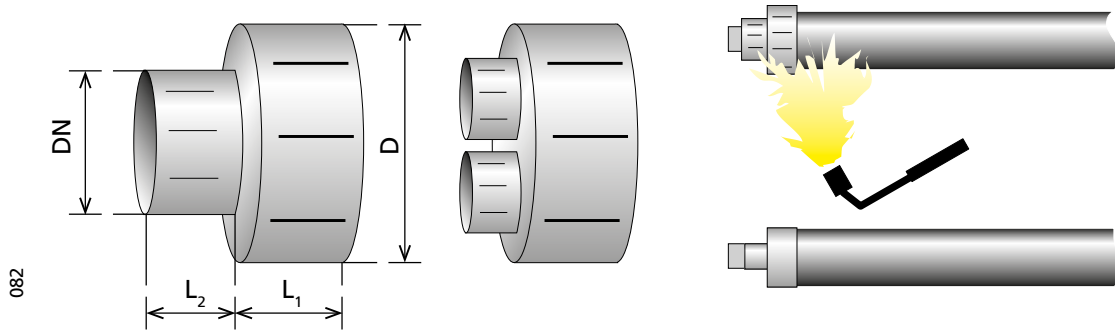

The end sealing of insulation must be attached to the pipe before welding the inner pipe. End sealing is shrunk by torch flame to protect the pipe end against moisture. Clean and abrade the jacket and pipe surface prior to shrinking. Start shrinking the seal part on the jacket section. Let it cool down and fasten before shrinking the part over the steel pipe. Avoid leaving air under the sealing.

DN	D (mm)	L ₁ (mm)	L ₂ (mm)
20-65	90-140	60	40
65-250	160-450	80	50
300-350	500	100	70

Code: Fintherm® Standard ES
(DN/casing diameter)
Ex.: FTS ES DN100/200

5.7 End fitting kit

The end fitting kit is used for the temporary blanking of a pipe. It is assumed that the ends blanked off by the kit will be used for a later extension of an existing route. The end of the heat transfer pipe must be closed off with a pressure steel bottom before foaming. The steel bottom should not touch the end of shrinkable casing. To reduce pipe stressing by pressure caused due to pipe movement in the ground, the face of the end fitting kit must be sheathed with an expansion pad.

The end fitting kit includes:

- | | | | |
|---------------------------|---------|------------------------------|--|
| 1. Steel bottom min. PN25 | 1 piece | 7. Welding plugs | 2 piece |
| 2. End shrinkable casing | 1 piece | 8. Detection wires connector | 1 piece |
| 3. Centring ring | 1 piece | 9. Sealing tape | 1 piece |
| 4. Shrink sleeve | 1 piece | PUR components | (quantity according to the dimensions) |
| 5. Closing patch | 1 piece | | |
| 6. Venting plugs | 2 piece | | |

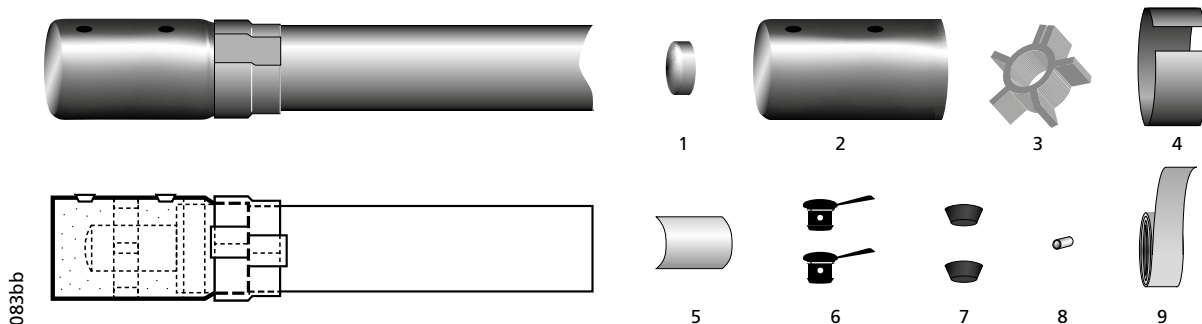

Code: Fintherm® Standard ECK-DSJ (DN/casing parameter)
Ex.: FTS ECK-DSJ DN100/200

Accessories

5.8 Connection pipe

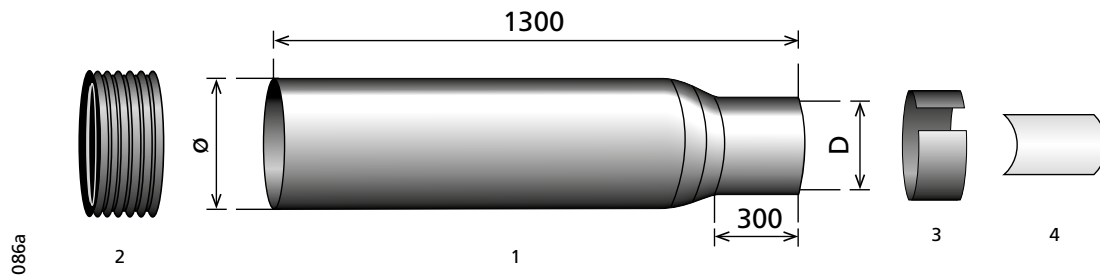

The connection pipes are used as an outlet for pre-insulated branches from concrete ducts. It ensures water tightness and enables axial movement of the main pipe in a concrete duct.

The kit includes:

- | | |
|--------------------------|---------|
| 1. Connection PE-HD pipe | 1 piece |
| 2. Channel rubber | 1 piece |
| 3. Narrow Shrink sleeve | 1 piece |
| 4. Closing patch | 1 piece |

Code: Fintherm® Standard CP
(casing diameter)
Ex.: FTS CP 125

Diameter of the casing pipe D (mm)	Ø (mm)
90	140
110	160
125	180
140	200
160	225
180	280
200	280
225	315
250	315
280	355
315	400
355	450

Accessories

5.9 Tapping valve

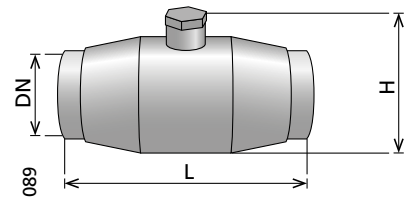
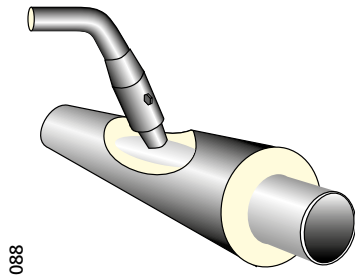

Standard reduced hot tapping valves:

DN	Inner pipe diameter DN	L (mm)	H (mm)
25	20	143	63
32	25	145	68
40	32	178	96
50	40	198	107
65	50	205	118
80	65	200	137
100	78	225	163
150	125	365	253
200	150	523	310

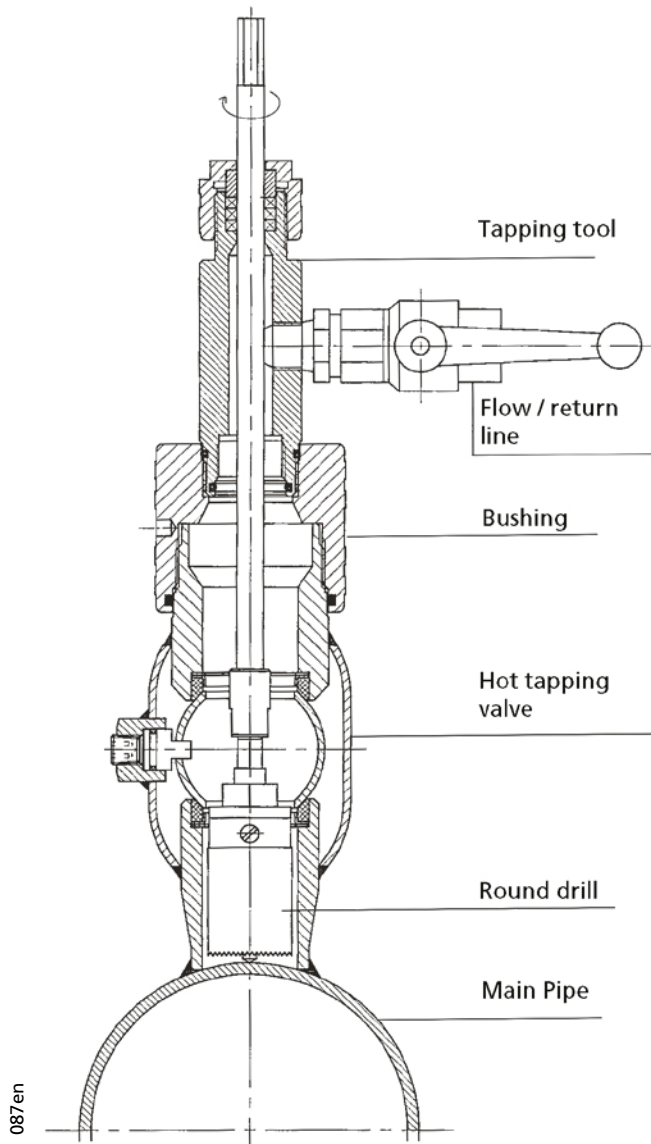

Full-flow hot tapping valves:

DN	Inner pipe diameter DN	L (mm)	H (mm)
25	25	209	75
32	32	207	91
40	40	226	107
50	50	260	125
65	65	280	148
80	80	312	175
100	100	349	211
125	125	365	253
150	150	520	310

This equipment enables drilling a branch hole into a pressurized pipe (hot tapping) without any need to drain the medium. When drilling the tap hole, the drill passes through a ball valve, which is welded on to the main pipe as a branch. The diameter range of the branch pipe that can be achieved with pipe tapping is from DN 25 to DN 200. FINTHERM® offers reduced or full-flow tapping versions. The tapping branch is additionally insulated with the T-kit (e.g., the Elevation model); see Chapter 1.5.5.

Important note: When tapping is performed, the temperature of the medium must not exceed 60°C and its maximum permissible pressure is 0,5 MPa.

Accessories

5.10 Polyethylene valve wells

Thanks to the telescopic polyethylene chamber, it is possible to take into account the individual requirements for the manhole height depending on how deep under the ground the pipe is installed. The handling and installation of the chamber is very simple, thanks to its compact design and low weight. In addition, the chamber does not transfer the load from the moving vehicles to the pipeline. There are two types of cast iron chamber covers, with the load capacity of 25 tonnes (type 1) and 40 tonnes (type 2).

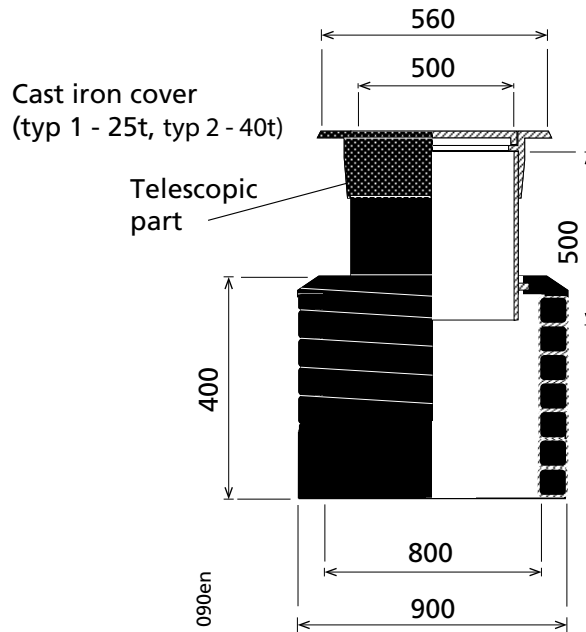

Installation methods:

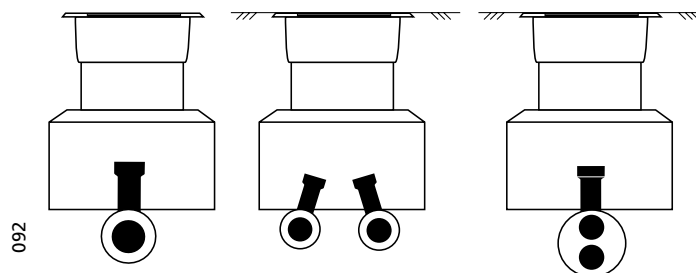

Other sizes are available on request.

The pre-defined versions are supplied at the lengths of 1 and 2 metres (the length can also be adjusted directly on site)

It must always be possible for the valves to move within the chamber; if installed under the ground, the whole spindle must be covered in expansion pads.

Code: Fintherm® Standard PE- well (800/900) (well cover type)
Ex.: FTS PE-well (inner/outer diameter), 1

Accessories

5.11 Valve spindle extender

Valve spindle extenders are used for cases in which a normal pre-insulated valve spindle is too short. Fixed version can be supplied. The solid rod extension is supplied in lengths from 1 m; 2 m. The length can be adjusted directly on a site.

Important notice:

Expansion of the valve in the shaft must be allowed for. When laid in ground, the entire valve rod must be sheathed with expansion pads.

The Solid valve spindle extender and valve spindle is covered by a protection pipe, which is sealed with a narrow shrink sleeve and Closing patch.

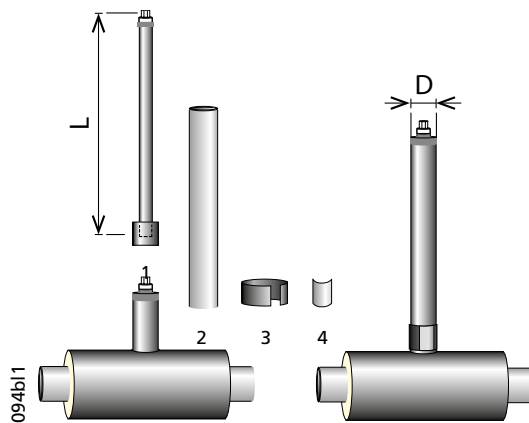

The solid extension of the valve rod includes:

1. Solid extension of the valve spindle
2. PE protection pipe
3. Narrow Shrink sleeve
4. Closing patch

Material of the valve rod extensions:

- Internal mechanism made of stainless steel.
- Extension casing:
 - DN25-DN80 – PE pipe (D=110 mm)
 - DN100-DN150 – PE pipe (D=140 mm)
 - DN200-DN250 – zinc coated steel hexagon (HX90)

Code: Fintherm® Standard SPE (DN of the valve) x (diameter of the PE protection pipe) (L=length)

Ex.: FTS SPE DN80 x 110 L = 1 m

5.12 Leakage detection system

FINTHERM pipe systems are manufactured with Nordic system detection wires as a standard, in line with EN 14 419. We can supply pipes with other types of detection wires (e.g., Brandes, Hagenuk, and Isotronic) upon request.

5.12.1 Detection principle

Pre-insulated pipe systems enable the electronic detection of any leakage of the carrier pipe and its casing. Detection wires serve as sensors, and are located in the insulation foam together with the carrier pipe. All pipes and joints are equipped with at least two wire sensors which connect into seamless sections in order to monitor the whole system. Special sensors are then connected to the individual sections.

Conductometry

Conductometry, i.e., the measurement of the electric conductivity of fluids, is the basis of operation for all sensor types. Leakage of fluid into the piping insulation layer creates a bridge between a detection wire and the pipe (or between two wires). If acceptable leakage is exceeded, a defect is signalled.

Reflectometry

The highest class in the field of leakage sensors consists of instruments operating on the principle of reflectometry - the measurement of electric signal reflections in a conductor. A defect (wet insulation, broken wire, short-circuit) is a disturbed electric homogeneity which induces a partial or total reflection of the electronic impulse, from which the instrument determines the nature and location of the fault.

Thanks to conductometry, it is also possible to measure electric capacity changes caused by fluids gradually proceeding through the foam towards the detection wires (before contact).

5.12.2 Sensors

Sensors can be divided into stationary and portable types based on the method of their use, and in turn into indicatory and localization types based on their ability to determine the distance of the fault.

Stationary sensors - located inside a suitable structure for permanent monitoring

Portable sensors - designed for operational measurements in any part of the system

Indicator sensors - only warn about a fault in a controlled section

Localization sensors - able to determine fault location as well

5.12.3 Selection of the detection system

An appropriate measuring device must be determined for each type of leak detection system for the pre-insulated piping. Please contact the FINTHERM® technical department, who will help you select the appropriate type according to your requirements and the sensor wires used.

6. Quality and Certifications

Quality and Certifications

6 Quality and Certifications

A satisfied customer is FINTHERM®'s priority, so it puts an emphasis on excellent quality and a continuous improvement process. All manufacturing materials and final products are subjected to thorough tests in the company's state-of-the-art laboratory staffed with experienced personnel.

FINTHERM® has been approved by Lloyd's Register Quality Assurance to the following Quality, Environmental and Safety Management System Standards for scope which is applicable to Design and manufacture of thermal pre-insulated pipe system:

- ISO 9001 - Quality Management Certification,
- ISO 14001 - Environmental Management Certification.
- OHSAS 18001 - Management System for Safety and Protection

All products meet the requirements of EN 253, 448, 488 EN 15698-1, and 489 European standards, as documented by a series of certificates from Czech and foreign test laboratories. The internationally recognized European Association Certification for EHP (EUROHEAT & POWER) and the German Association AGFW, which covers all the requirements for district heating products, are also evidence of the company's high quality standards. FINTHERM® is accredited by institute for installation joints assembly according to German standards FW 603 and FW 605 and in compliance with the AGFW.



IMS (ISO & OHSAS)



EUROHEAT & POWER



TZÚS



FW 605



FERNWÄRME FORSCHUNGSINSTITUT

NOTES

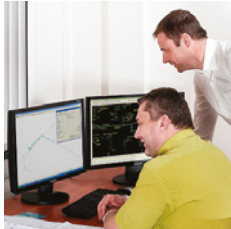

FINTHERM is the leading Czech company in the production of pre-insulated pipelines and fittings for underground or above-ground distribution lines for heat, cold, condensate, hot water, other media, and other applications, and which also exports pre-insulated pipes to many other countries.



For more technical information, please visit web site at www.fintherm.cz



FINTHERM a.s.
Za Trati 197
196 00 Prague 9
Czech Republic

T +420 283 980 910
M +420 725 933 120
www.fintherm.cz